

CertainTeed WeatherBoards™

# Fiber Cement Siding

Installation Manual



**CertainTeed** 

Quality made certain. Satisfaction guaranteed.™



# Table of Contents

Glossary .....	2	<b>Section 8: Wall Preparation and Sheathing</b> .....	27
Top 10 Fiber Cement Installation Tips .....	4	Sheathings .....	27
<b>Section 1: Before You Begin</b> .....	6	New Construction .....	28
First Steps to a Successful Project.....	6	Remodeling .....	28
<b>Section 2: Estimating</b> .....	7	Stucco.....	28
Siding .....	7	Concrete Block (CMU) and Poured	
Soffit .....	7	Concrete Walls .....	28
Porch Ceiling .....	7	Flashing .....	29
Trim .....	8	CertaFlash BA around Windows .....	29
Estimating Form .....	10	<b>Section 9: Trim</b> .....	30
Coverage Chart .....	11	Fascia, Band and Frieze Boards, and Rakes.....	31
<b>Section 3: Safety</b> .....	12	<b>Section 10: Lap Siding</b> .....	32
Ventilation .....	12	Before You Begin .....	32
Ladders.....	12	Blind Fastening.....	33
Tools .....	13	Face Fastening .....	33
Fastening Tools .....	13	Installation.....	34
Personal Protective Equipment (PPE) .....	13	Butt and End Joint Application .....	36
Air Compressors .....	14	Creating Laced (Prairie-Style) Corners.....	38
<b>Section 4: Storage and Handling</b> .....	14	<b>Section 11: Shapes Siding</b> .....	38
<b>Section 5: Tools and Accessories</b> .....	15	Before You Begin .....	38
Cutting & Drilling .....	15	Perfection Shingles .....	39
Fastening .....	17	Random Square Straight Edge and	
Alignment .....	17	Staggered Edge .....	39
Accessories .....	17	Individual Shakes.....	42
Aluminum Molding & Trim .....	17	Octagons and Half-Rounds.....	44
Backflashing .....	17	<b>Section 12: Vertical Siding</b> .....	47
<b>Section 6: Cutting</b> .....	18	Before You Begin .....	47
Personal Protective Equipment (PPE) .....	18	Installing Panels.....	48
Cutting Tools and Blades .....	18	<b>Section 13: Soffit</b> .....	50
Requirements .....	18	Before You Begin .....	50
<b>Section 7: Fastening</b> .....	19	Ventilation.....	51
Nails .....	19	Installation.....	52
Screws .....	19	<b>Section 14: Porch Ceiling Panels</b> .....	52
Acceptable Fastening Alternatives .....	20	<b>Section 15: Finishing</b> .....	54
Fastening to Structural Materials .....	20	Caulking.....	54
Fastening Requirements for Atypical Walls .....	22	Painting .....	55
Structural Insulated Panels .....	22	Staining .....	55
Concrete Masonry (CMU)		<b>Section 16: Care and Maintenance</b> .....	55
or Poured Concrete Walls.....	23	Periodic Maintenance and Care .....	55
Structural Rainscreens		Washing .....	56
(Steel Studs/Steel Furring Strips) .....	24	Protecting Fiber Cement Siding .....	56
Non-structural Rainscreens .....	24	Recaulking .....	56
Insulated Concrete Forms .....	25	Touch-ups .....	57
Fastening Requirements for Weatherboards		Mildew.....	57
Fiber Cement Siding.....	26	Refinishing .....	57
		Efflorescence .....	58

## Glossary

Because this manual was written for building professionals, we have freely used the language and jargon of the siding industry. To avoid confusion, we thought it a good idea to share our understanding of each of these terms with you.

**Back Sealing/Back Priming**—Applying a sealer or primer to the back of a cladding material. This practice is not recommended with CertainTeed Fiber Cement.

**Backflashing**—A durable, non-corrosive material used to flash water away from the butt joints of lap siding.

**Band Board**—A decorative piece of horizontal trim placed between two floors along the rim joist.

**Beaded**—A narrow, half-round molding at the base of a lap siding panel.

**Blind Nailing**—Fastening through the top edge of lap siding so that the fastener head will be covered by the next course of siding.

**Butt end/Joint**—A joint created by placing edges of lap siding end-to-end without overlapping.

**Casing**—Molding of various widths used to trim door and window openings at the jambs; also referred to as lineal, window, or door surround.

**Contraction**—Commonly refers to building products contracting due to heat loss or moisture leaving the product, especially as outside temperature changes.

**Course**—A row of siding panels running the width of the house.

**Dormer**—A gabled extension built out from a sloping roof to accommodate a vertical window.

**Drip Cap**—A horizontal flashing placed over exterior door or window frames to divert rainwater.

**Dutchlap**—Refers to a drop-style panel that was popularized by early American settlers in the seaboard states; lap siding panel with a horizontal bevel at the top of the panel that sits just below the bottom of the next course of siding.

**Eave**—The overhang of a pitched roof at the bottom edge, usually consisting of a fascia board, a soffit for a closed cornice, and appropriate moldings.

**Expansion**—Commonly refers to building products expanding due to heat build-up or moisture entering the product, especially as outside temperature changes.

**Exposure**—The width of the exposed face of each panel of siding; also referred to as reveal.

**Face**—The side of the siding, trim, or soffit that is exposed to view after the product has been installed.

**Face Nailing**—Fastening through both the overlapping and the overlapped panel; the fastener head will be visible.

**Fascia**—A flat, horizontal band that covers the rafter tails and runs along the bottom edge of the roof line.

**Flashing**—A thin, impervious material, usually metal, placed around openings to prevent water penetration or to direct the flow of water over the cladding.

**Frieze**—The horizontal trimboard connecting the top of the siding with the soffit.

**Furring/Furring Strip**—Long, thin strips of wood or other materials used to build out the fastening surface of a wall; commonly used to correct imperfections in wall surfaces, to establish a rainscreen, or to re-establish a structural fastening surface on the exterior of non-structural products such as foam insulation.

**Gable**—The triangle formed on the side or the front of a building by a sloping roof.

**Hot-dip Galvanized**—The process of dipping metal into molten zinc to apply a protective coating that prevents corrosion; hot-dipped galvanized iron and steel are corrosion resistant.

**H-channel Joint**—When installing vertical siding or soffit materials, used to conceal the edges; with lap siding, H-channel or joint covers are used to cover the butt ends/joints where they come together (mainly for aesthetic purposes).

**Joint Flashing**—A durable, non-reactive material placed behind a butt end/joint to help shed water; commonly made of finished metal or #15 felt.

**Keyway**—A recess or groove in a manufactured shake or shingle siding panel.

**Lap**—Where two siding panels join horizontally, one over the other.

**Lineal**—Molding of various widths used to trim door and window openings at the jambs; also referred to as casing, window, or door surround.

**Miter Cut**—A beveled cut, usually 45°, made at the end of a piece of molding or board that is used to form a mitered joint.

**MSF**—1,000 sq. ft. of material; due to a 1-1/4" overlap (or 15% "loss" for lap), the actual coverage of 1,000 sq. ft. for lap siding is 850 sq. ft.

**O.C.**—On center; a measurement of the distance between the centers of two repeating members in a structure, usually studs.

**OSB**—Oriented Strand Board.

**Panel Projection**—The distance that the bottom edge of the siding projects from the wall.

**Profile**—The contour or outline of a siding panel as viewed from the side.

**Rainscreen Wall**—A method of constructing walls in which the cladding is separated from a membrane by an airspace that allows pressure equalization to prevent rain from being forced in. It consists of an exterior cladding, a cavity that is typically created through the use of furring strips behind the cladding, and an inner wall that incorporates a weather-resistant barrier.

**Rake**—Trim members of a gable roof that run parallel to the roof slope from the eave to the ridge.

**Rigid Sheathing**—Plywood, OSB, or foam sheathing.

**Rim Joist**—The board that the rest of the joists are nailed to. It runs the entire perimeter of the house.

**Rip Cut**—A cut made along the grain, usually lengthwise on a board.

**Kick-Out Diverter Flashing**—A flashing piece located where sloped roofs meet vertical walls; designed to divert water into a gutter.

**Sealant**—A waterproof filler and sealer that is used in building and repair to make a surface watertight.

**Sheathing**—Sheets of plywood, exterior gypsum board, or other material nailed to the outside face of studs as a base for exterior siding.

**Shim**—A building material, usually wood, used to even a surface.

**Skirtboard**—Treated lumber or PVC trimboard installed horizontally; used as a transition from foundation to siding or as a starter strip.

**Soffit**—The underside of an overhanging eave.

**Square**—Unit of measure for siding; equal to 100 square feet of exposure (e.g. a 10-ft. by 10-ft. wall section = 100 square feet = 1 Square).

**Starter Strip**—An accessory used under the first course of siding to provide a consistent panel angle.

**Structural Member**—A support that is a constituent part of any structure or building.

**Structural Sheathing**—The layer of boards, wood or fiber materials applied to the outer studs, joists, and rafters of a building to strengthen the structure and serve as a base for an exterior cladding.

**Substrate**—A layer of material applied over the studs at the exterior walls of a building.

**Weather-Resistant Barrier**—A building membrane that protects building materials from exterior wind and water penetration.

**Z-flashing**—A piece of flashing bent into the shape of a "z" and used to divert water from horizontal joints over window trim, band boards, panel intersections, and other vertical surfaces.

**NOTE: When the terms "recommend" and "should" are used in this manual, the step is optional for installing fiber cement. However, it is included because the step represents best practice.**

**When the terms "required" and "must" are used, the step is a necessary part of the installation process and must be adhered to.**

# Top 10 Fiber Cement Installation Tips

	DO	DON'T
1 Before You Begin	<ul style="list-style-type: none"> <li>▶ Review this manual in its entirety and all applicable building codes prior to installation.</li> <li>▶ Wear appropriate safety equipment—dust mask or respirator, eye protection, hard hat, and cut-resistant gloves as appropriate.</li> </ul>	<ul style="list-style-type: none"> <li>▶ Do not install questionable product. If you have questions about the product, contact CertainTeed Consumer Service Group at 800-999-3654.</li> </ul>
2 Storage & Handling	<ul style="list-style-type: none"> <li>▶ Keep siding covered, off the ground on a clean, flat, and level surface that is protected from direct exposure to weather.</li> <li>▶ Carry lap siding by its narrow edge.</li> </ul>	<ul style="list-style-type: none"> <li>▶ Do not install wet siding.</li> </ul>
3 Flashing	<ul style="list-style-type: none"> <li>▶ Use durable, non-corrosive flashing that is non-reactive with fiber cement.</li> <li>▶ Maintain 1/4" clearance between the bottom of the fiber cement and horizontal flashing.</li> </ul>	<ul style="list-style-type: none"> <li>▶ Do not use uncoated aluminum or metal materials.</li> <li>▶ Do not caulk "Z" flashing at horizontal openings.</li> </ul>
4 Sheathing & Wraps	<ul style="list-style-type: none"> <li>▶ Install lap siding and vertical siding to structural framing when using non-structural sheathing, builder board, foam-type sheathings, and gypsum board.</li> <li>▶ See the recommendations on page 22 before installing fiber cement siding over Structural Insulated Panels thicker than 1".</li> <li>▶ Install Individual Shakes over wall construction with framing spaced no more than 24" o.c. and a minimum of 7/16" OSB or 1/2" plywood sheathing.</li> <li>▶ Apply siding over a weather-resistant barrier in accordance with local building code. CertainTeed CertaWrap™ qualifies as a weather-resistant barrier that meets local building code requirements.</li> </ul>	<ul style="list-style-type: none"> <li>▶ Do not fasten fiber cement siding over non-structural sheathing thicker than 1" without re-establishing a structural fastening surface.</li> </ul>
5 Fasteners	<ul style="list-style-type: none"> <li>▶ Use non-corrosive, double hot-dipped galvanized or stainless steel nails.</li> </ul>	<ul style="list-style-type: none"> <li>▶ Do not use D-head nails, staples, finishing nails and/or construction adhesives to install fiber cement siding.</li> </ul>
6 Clearances	<ul style="list-style-type: none"> <li>▶ Hold back siding a minimum of 6" above the finished grade.</li> <li>▶ Allow a minimum of 1"-2" above roof lines, porches, decks, etc.</li> <li>▶ Leave 1/8" gap between siding and trim surrounding windows and doors.</li> </ul>	<ul style="list-style-type: none"> <li>▶ Do not install fiber cement directly in contact with surfaces that collect water.</li> <li>▶ Do not install fiber cement products tight against trim.</li> </ul>

	<b>DO</b>	<b>DON'T</b>
7 Cutting	<ul style="list-style-type: none"> <li>▶ Use appropriate personal protective equipment (PPE).</li> <li>▶ Refer to page 18 for details.</li> <li>▶ Cut fiber cement outdoors when possible.</li> <li>▶ Use a polycrystalline diamond-tipped fiber cement blade for circular, miter, and table saws.</li> <li>▶ When using a circular saw or mechanical shears, cut fiber cement siding face down.</li> <li>▶ When using a chop saw cut the siding face up.</li> <li>▶ If WeatherBoards™ Fiber Cement Lap Siding with CertainTeed ColorMax® Finish is covered by protective film, leave the film on the siding until it is nailed to the substrate; then remove it before applying the next course.</li> <li>▶ If protective foam is inserted between siding panels, remove it before cutting or installing fiber cement panels.</li> </ul>	<ul style="list-style-type: none"> <li>▶ Do not score and snap fiber cement.</li> <li>▶ Do not cut fiber cement without proper ventilation.</li> </ul>
8 Butt Joints	<ul style="list-style-type: none"> <li>▶ Re-seal cut ends with 100% acrylic latex primer or paint.</li> <li>▶ Install all butt ends/joints in contact with one another.</li> <li>▶ Use durable, non-corrosive backflashing that is non-reactive with fiber cement at all butt joints.</li> </ul>	<ul style="list-style-type: none"> <li>▶ Never leave a gap at a butt joint.</li> <li>▶ Do not use uncoated aluminum or metal materials with fiber cement siding.</li> </ul>
9 Fastening	<ul style="list-style-type: none"> <li>▶ Nails must penetrate a minimum of 1-1/4" into structural framing.</li> <li>▶ Fasten only to structural rated sheathing like 7/16" OSB or 1/2" plywood.</li> <li>▶ Keep fasteners proud to the surface of material.</li> <li>▶ Nail 1" down from the top of the board when blind nailing.</li> <li>▶ Nail 3/4" up from the bottom when face nailing.</li> </ul>	<ul style="list-style-type: none"> <li>▶ Do not counter sink or angle fasteners.</li> </ul>
10 Painting & Caulking	<ul style="list-style-type: none"> <li>▶ Use high quality 100% acrylic latex paint or stain.</li> <li>▶ Use high quality, exterior grade, color matched or paintable caulk or sealant that meets ASTM standard C-920 and is compatible with both fiber cement siding and the trim materials.</li> <li>▶ Be sure to caulk wherever the siding meets the trim and around non-self-flashing penetrations and all windows and doors.</li> </ul>	<ul style="list-style-type: none"> <li>▶ Never apply oil-based paint or stains.</li> <li>▶ Do not caulk the bottom of the horizontal joint that is above "Z" flashing.</li> </ul>

# Section 1: Before You Begin

Please read the instructions **completely**. The installation techniques in this manual describe and illustrate the steps involved in installing WeatherBoards™ Fiber Cement siding, soffit, and trim. Their purpose is to provide detailed information and how-to tips that will simplify the installation process. CertainTeed will not accept any liability or responsibility under its written warranty for product failure caused by application that does not meet the requirements for proper installation. These requirements are outlined throughout this book.

Before you begin any siding project, you need to be aware of building code requirements in the geographic areas where you are working, and how the codes relate to the instructions given in this manual and by the siding manufacturer. You must always observe the requirements of local building codes because they represent the legal requirements for an installation in a given jurisdiction. However, most local codes are based on the national model building codes. Model codes themselves do not have the force of law until they are adopted by a state or local jurisdiction. In the United States, the primary source of model codes is the International Code Council ([www.iccsafe.org](http://www.iccsafe.org)), which publishes the International Building Code (IBC) and International Residential Code (IRC). In Canada, the primary model code is the National Building Code (NBC), published by the National Research Council of Canada ([www.nrc-cnrc.gc.ca](http://www.nrc-cnrc.gc.ca)).

No instruction manual can anticipate all the questions or conditions that might arise during installation. Recognizing this, we've focused on the tools and techniques used to complete typical installations. If you encounter an installation situation not covered in this manual, we suggest you contact CertainTeed's Sales Support Group at 800-233-8990.

## First Steps to a Successful Project

Before installing any material, inspect it for breakage, foreign objects, surface defects, correct product, correct color, and color consistency. In addition, check for wet or saturated product. Do not install questionable product!

If you find a siding defect, contact CertainTeed's Consumer Service Group immediately at 800-999-3654.

If you elect to install questionable product and a manufacturing defect is not found to be the source of the problem, any claim may not be honored.

Before you begin to work with fiber cement siding, it is important that you and the members of your crew have read and understand the information in this guide, particularly:

- ▶ Safety
- ▶ Storage and Handling
- ▶ Cutting and Fastening
- ▶ Wall Preparation

Also, review the instructions for the particular siding product you will install (Lap, Vertical, or Shapes) and assemble the right tools, fasteners, and accessories before you begin.

### An important note about CertainTeed warranties:

Failure to comply with CertainTeed installation instructions and/or applicable building codes may affect product performance and void the product warranty. Please refer to ICC-ES ESR-1668 and other technical information available at [www.certainteed.com](http://www.certainteed.com)



## Section 2: Estimating

### Siding

Use the illustrations and formulas below and enter totals on the estimating form in this section. These formulas apply for both horizontal and vertical installations.

**NOTE: Depending on the pitch of the roof, gables and more cut-up areas will produce a higher scrap rate.**

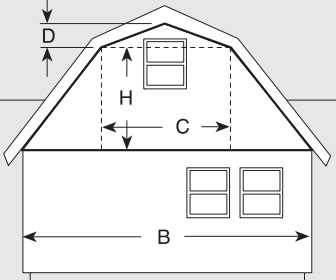
<p><b>Rectangular wall surfaces</b></p> <p>Measure height (excluding gables). Measure width (including doors and windows). Repeat for remaining walls.</p>	$\frac{\text{_____}}{\text{(height)}} \times \frac{\text{_____}}{\text{(width)}} = \frac{\text{_____}}{\text{(surface area)}}$
<p><b>Triangular gable end surfaces</b></p> <p>Measure height at center (add 1' to allow for waste). Measure width and divide by half. Repeat for remaining gables.</p>	$\frac{\text{_____}}{\text{(height)}} \times \frac{\text{_____}}{\text{(1/2 width)}} = \frac{\text{_____}}{\text{(surface area)}}$
<p><b>Upper wall of gambrel house</b></p> <p>Divide the upper wall of a gambrel house. Then use these formulas: Repeat for remaining gambrel surfaces.</p>	 <p> <math display="block">\frac{1}{2} (B+C) \times H = \text{_____}</math> <math display="block">+ \frac{1}{2} C \times D = \text{_____}</math> </p> <p>Add to get total area: _____</p>
<p><b>Dormer sides</b></p> <p>Measure the height of the dormer (add 1' to allow for waste). Use these formulas: Repeat for all dormers.</p>	$\frac{\text{_____}}{\text{(1/2 height)}} \times \frac{\text{_____}}{\text{(1/2 width)}} = \frac{\text{_____}}{\text{(surface area, 1 side)}}$ $\frac{\text{_____}}{\text{(surface area, 1 side)}} \times 2 = \frac{\text{_____}}{\text{(total dormer surface area)}}$

### Soffit

<p>Measure width of eave to be covered. Measure length of eave. Repeat for remaining eaves.</p>	$\frac{\text{_____}}{\text{(length)}} \times \frac{\text{_____}}{\text{(width)}} = \frac{\text{_____}}{\text{(surface area)}}$
---	--

### Porch Ceiling

<p>Measure length of porch area to be covered. Measure width of porch.</p>	$\frac{\text{_____}}{\text{(length)}} \times \frac{\text{_____}}{\text{(width)}} = \frac{\text{_____}}{\text{(surface area)}}$
--	--

## Trim

Insert the number of lineal feet or the number of pieces

7/16" (actual) Trim/Fascia							
	3-1/2"	5-1/2"	7-1/4"	9-1/4"	11-1/4"		
Front							
Left							
Right							
Rear							
4/4" (nominal) Trim							
	2"	3"	4"	6"	8"	10"	12"
Front							
Left							
Right							
Rear							
5/4" (nominal) Trim							
	3"	4"	5"	6"	8"	10"	12"
Front							
Left							
Right							
Rear							

## Restoration Millwork Exterior Trim

One-Piece Corners							
	5/4" x 4"	5/4" x 4" J-Pocket	5/4" x 6"	5/4" x 6" J-Pocket	Inside Corner		
Front							
Left							
Right							
Rear							
5/8" (nominal) Trimboards							
	4"	6"	8"	10"	12"		
Front							
Left							
Right							
Rear							
1" (nominal) Trimboards							
	4"	6"	8"	10"	12"	16"	
Front							
Left							
Right							
Rear							

5/4" (nominal) Trimboards								
	4"	4" J-Pocket	6"	6" J-Pocket	8"	10"	12"	16"
Front								
Left								
Right								
Rear								

Decorative Trim Boards					
	Brickmould	J-Channel	#49 Crown	#47 Crown	#45 Crown
Front					
Left					
Right					
Rear					
	Rams Crown	Base Cap	Rake	Quarter Round	Drip Cap
Front					
Left					
Right					
Rear					
	Shingle Mould	Bed Mould	Lattice	Sill Nose	Sill
Front					
Left					
Right					
Rear					
	356 Casing	RB3 Casing	Back Band	Adjustable Back Band	Skirtboard
Front					
Left					
Right					
Rear					

Adhesives	
Bond & Fill®	TrimTight™
_____	_____

## Estimating Form

<b>Siding<sup>1</sup></b>	Walls	_____	ft <sup>2</sup>
	Gable ends	_____	ft <sup>2</sup>
	Dormer sides	_____	ft <sup>2</sup>
	Upper gambrel walls	_____	ft <sup>2</sup>
	Total wall surface area	_____	ft <sup>2</sup> (A)
<b>Areas not to be covered</b>	Garage doors/sliding glass doors	_____	ft <sup>2</sup> x .5 = (B)
	<b>Subtract B from A for total net surface area</b>	_____	ft <sup>2</sup>
<b>Soffit</b>		_____	ft <sup>2</sup>
<b>Porch</b>		_____	ft <sup>2</sup>
<b>Ceiling</b>		_____	ft <sup>2</sup>
<b>Fasteners</b>	Nail gun nails	_____	coils
	Hand nails	_____	lbs
	Screws	_____	lbs

<sup>1</sup> If you are using multiple profiles on the same project (e.g., Shapes, lap siding, and vertical panels), you will have to calculate the amount of siding to be used for each profile separately.

## Coverage Chart

This chart indicates the number of pieces of WeatherBoards Fiber Cement siding you will need. It does not include waste, and all numbers have been rounded up.

LAPS							SHAPES			PANELS		
	5-1/4"	6-1/4"	7-1/4"	8-1/4"	9-1/4"	12"	8-1/4" Perfection Shingles	Random Sq. Edge 12"	Random Sq. Edge 16", Random Sq. Staggered Edge, Half-Rounds & Octagons	4' x 8'	4' x 9'	4' x 10'
<b>Overlap</b>	1.25	1.25	1.25	1.25	1.25	1.25	1.25	7.00	9.00	—	—	—
<b>Exposure</b>	4.00	5.00	6.00	7.00	8.00	10.75	7.00	5.00	7.00	—	—	—
<b>Squares*</b>												
1	25	20	17	15	13	10	15	60	43	4	3	3
2	50	40	34	29	25	19	29	120	86	7	6	5
3	75	60	50	43	38	28	43	180	129	10	9	8
4	100	80	67	58	50	38	58	240	172	13	12	10
5	125	100	84	72	63	47	72	300	215	16	14	13
6	150	120	100	86	75	56	86	360	258	19	17	15
7	175	140	117	100	88	66	100	420	300	22	20	18
8	200	160	134	115	100	75	115	480	343	25	23	20
9	225	180	150	129	113	84	129	540	386	29	25	23
10	250	200	167	143	125	93	143	600	429	32	28	25
11	275	220	184	158	138	103	158	660	472	35	31	28
12	300	240	200	172	150	112	172	720	515	38	34	30
13	325	260	217	186	163	121	186	780	558	41	37	33
14	350	280	234	200	175	131	200	840	600	44	39	35
15	375	300	250	215	188	140	215	900	643	47	42	38
16	400	320	267	229	200	149	229	960	686	50	45	40
17	425	340	284	243	213	159	243	1,020	729	54	48	43
18	450	360	300	258	225	168	258	1,080	772	57	50	45
19	475	380	317	272	238	177	272	1,140	815	60	53	48
20	500	400	334	286	250	186	286	1,200	858	63	56	50
21	525	420	350	300	263	196	300	1,260	900	66	59	53
22	550	440	367	315	275	205	315	1,320	943	69	62	55
23	575	460	384	329	288	214	329	1,380	986	72	64	58
24	600	480	400	343	300	224	343	1,440	1,029	75	67	60
25	625	500	417	358	313	233	358	1,500	1,072	79	70	63

\* 1SQ = 100 ft<sup>2</sup>

## Section 3: Safety

### Ventilation

When fiber cement is cut or drilled, it will create dust. This dust may contain crystalline silica, which can pose a health risk. To ensure adequate ventilation, work outdoors or use mechanical ventilation to reduce potential exposure to below OSHA Permissible Exposure Limits (PELs).

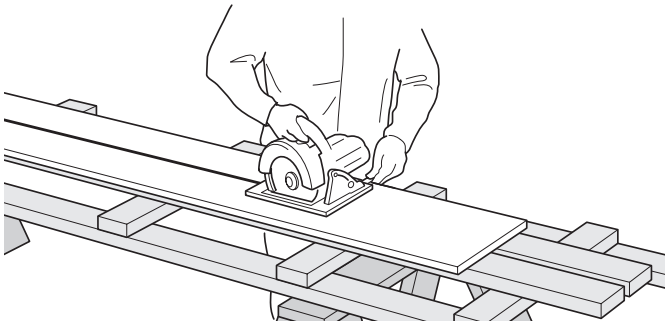

**IDEAL:** Cut outdoors and use cutting tools that minimize dust.

If ventilation is not adequate to limit exposure, wear a NIOSH-approved disposable respirator (N95) or air purifying cartridge respirator fitted with N (non-oil), P, or R series filters.



**CUTTING INDOORS:** Play it safe by providing good ventilation and wearing a respirator.

For more information on OSHA Permissible Exposure Limits, go to [www.osha.gov/SLTC/pel/](http://www.osha.gov/SLTC/pel/) More information about Respiratory Protection is available at [www.osha.gov/SLTC/respiratoryprotection/index.html](http://www.osha.gov/SLTC/respiratoryprotection/index.html)

### Ladders

**New OSHA Fall Protection regulations are in effect.**

STD 03-11-002 compliance guidance for residential construction was issued on Dec. 6, 2010, and went into effect June 16, 2011. For more information, visit [www.OSHA.gov](http://www.OSHA.gov) or consult your local state OSHA plan.

- ▶ Maintain ladders free of oil, grease, and other slipping hazards.
- ▶ Do not load ladders beyond their maximum intended load nor beyond their manufacturer's rated capacity.
- ▶ Use ladders only for their designed purpose.
- ▶ Use ladders only on stable and level surfaces unless secured to prevent accidental movement.
- ▶ Do not use ladders on slippery surfaces unless secured or provided with slip-resistant feet to prevent accidental movement. Do not use slip-resistant feet as a substitute for exercising care when placing, lashing or holding a ladder up on slippery surfaces.
- ▶ Secure ladders placed in areas such as passageways, doorways, or driveways, or where they can be displaced by workplace activities or traffic to prevent accidental movement. Or use a barricade to keep traffic or activity away from the ladder.
- ▶ Keep areas clear around the top and bottom of ladders.
- ▶ Do not move, shift, or extend ladders while in use.
- ▶ Use ladders equipped with nonconductive side rails if the worker or the ladder could contact exposed energized electrical equipment.
- ▶ Face the ladder when moving up or down.
- ▶ Use at least one hand to grasp the ladder when climbing.
- ▶ Do not carry objects or loads that could cause loss of balance and falling.
- ▶ Do not use ladders as a horizontal work platform.

## Tools

One of the most important things you can do to make the job go smoothly is to make sure that all tools are in good shape and everyone understands how to use them properly.

- ▶ Maintain all hand tools and equipment in a safe condition and check regularly for defects. Do not use broken or damaged tools.
- ▶ Use double insulated tools or ensure that all tools are grounded. Protect all power tools with ground fault circuit interrupters (GFCI). Plug into GFCI-protected generators or use GFCI extension cords.
- ▶ Equip all power saws with blade guards and turn them off when they are not in use.
- ▶ Before you or your crew use pneumatic or power-activated tools, make sure everyone has been trained and checked out on their proper use.
- ▶ Shear-type tools will cause little dust emissions. However, using polycrystalline diamond-tipped and carbide-tipped blades will create dust.

## Tools for Fastening

- ▶ A pneumatic nail gun designed for siding applications is faster than hand nailing. When using a pneumatic nailer for installing fiber cement siding to wood, adjust the air pressure to meet job site conditions, typically 80–85 psi.

**Big Sky Adapter**

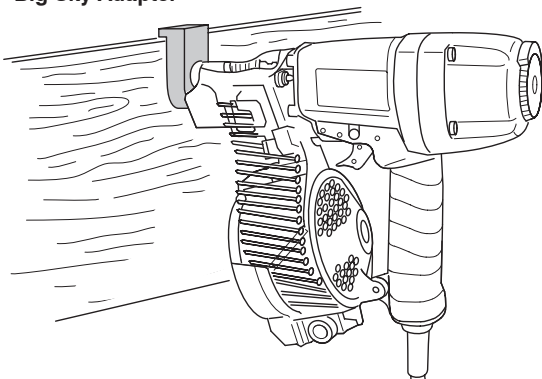

### IDEAL: Pneumatic Nailers

Do not use framing nail guns to apply fiber cement because they will over drive nails. Do not use finishing nail guns or staplers.

- ▶ Fiber cement siding can be hand nailed. Do not over drive the nail; seat the bottom of the nail head flush with the surface of the nail. When hand nailing face-nailed rake-angle cuts, you may have to predrill the holes.
- ▶ We recommend using a Big Sky adapter ([www.bigskyadapter.com](http://www.bigskyadapter.com)) to maintain proper nail placement when blind nailing.

## Personal Protective Equipment (PPE)

OSHA requires that workers wear applicable personal protective equipment.

- ▶ Falling debris is a hazard when installing siding and accessories. All workers and visitors should wear hard hats while they are on the jobsite.
- ▶ When cutting or nailing siding and accessories, wear cut-resistant gloves and ANSI Z87-approved eye protection or face shields.
- ▶ Wear sturdy shoes or boots to prevent or minimize foot injuries.

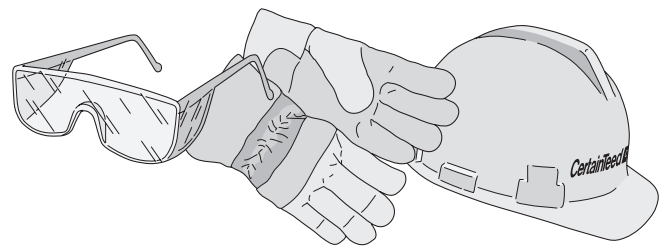

### Wear Safety Equipment

Work safely and use the proper precautions.

More information about personal protective equipment is available at [www.osha.gov/SLTC/personalprotectiveequipment](http://www.osha.gov/SLTC/personalprotectiveequipment)

Consult the WeatherBoards Material Safety Data Sheet (MSDS) on our website [www.certainteed.com](http://www.certainteed.com) and a qualified industrial hygienist for further health and safety information related to this product.

## Air Compressors

Air compressors can be very dangerous and cause serious injury if used improperly, so before you begin to use your air compressor, set it up properly to ensure safe operation.

- ▶ Locate the air compressor in an area that is free and clear from dust and debris. Excessive dust and debris will clog the filter and may even damage the internal components of the compressor.
- ▶ Limit the length of hose and the number of splits between the compressor and the nail gun.
- ▶ Set the air pressure regulator on the air compressor to the appropriate PSI setting and test the pressure for over/under driving the fastener on a scrap piece.

**NOTE: Always turn the air compressor off and drain the air out of the tank before connecting or disconnecting air tools. Failure to do this may result in serious injury.**

## Section 4: Storage and Handling

WeatherBoards Fiber Cement must be kept covered and stored off the ground, on a clean, flat, and level surface. Before it is installed, fiber cement should also be protected from direct exposure to the weather. CertainTeed recommends that pallets be stored in a garage, under a protected area or under a tarp because fiber cement siding that is wet can become heavy and more flexible, making it difficult to carry and install. Also, the joints between the panels can swell or shrink if fiber cement gets wet before it is installed. If WeatherBoards Fiber Cement siding becomes wet, it must dry completely prior to installation.

**NOTE: Do not install fiber cement material that is wet. Installing wet or saturated boards may result in the butt or end joints shrinking or swelling after installation.**

### Proper Storage

WeatherBoards Fiber Cement siding is coated with our FiberTect® Sealing System to protect against moisture. However, even with this sealer, the product can become saturated if not protected during storage. If fiber cement becomes saturated, do not install it until it dries out thoroughly.

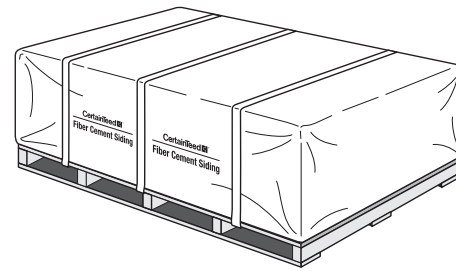

**Proper Storage:** Store covered, on pallets.

- ▶ Do not store fiber cement siding or trim directly on the ground. If a covered area such as a garage is not available on the jobsite, place pallets on wood blocks to allow air flow underneath the pallet.
- ▶ If palletized fiber cement is to be placed on a damp surface, place a vapor barrier on the ground underneath the pallet.
- ▶ Use the plastic bonnet provided to keep the product dry and prevent moisture from settling on the siding. If you expect snow or rain, cover the bonnet with a tarp.

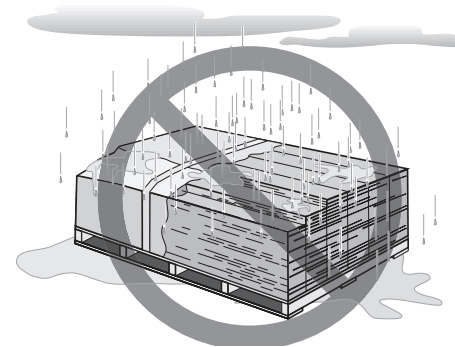

**Improper Storage**

- ▶ If the siding is packaged with slip sheeting, ensure that the slip sheeting stays between the boards to protect against marring the surface, boards sticking together, and moisture.

**NOTE: Pay particular attention to the top two or three rows of siding on the pallet, as these boards are more likely than others to absorb moisture. For best results, we suggest you not install the top two or three rows of siding on a pallet until you are absolutely certain that they are dry.**

**NOTE: Wet boards are visibly darker in color, while dry boards are a lighter grey tone.**

**NOTE: Many issues can be traced back to storage and handling issues. Best practice is to put an additional layer of plastic or a tarp over the pallets when they are on site.**



## Proper Handling

- ▶ Always carry fiber cement boards by holding the narrow edge.

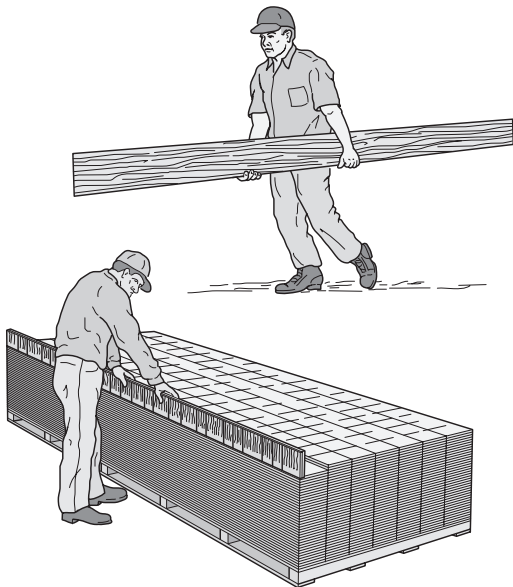

**Proper Handling**

Pick up the boards from the center; carry by the narrow edge.

- ▶ If handled incorrectly, the surface of prefinished boards will scratch.
- ▶ Do not slide boards when removing them from the pallet as sliding one board against the other will mar the surface of the board below. Always pick up the boards from the center.

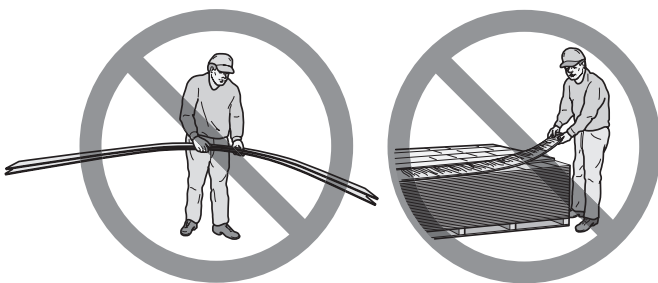

**Improper Handling:** When carrying fiber cement boards, support the product along its length.

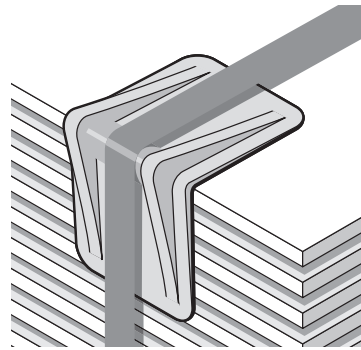

### Corner Protectors

Reduce the risk of marring the surface.

- ▶ Always use corner protectors when banding fiber cement siding or trim.
- ▶ The outside face of CertainTeed WeatherBoards Fiber Cement Cedar Lap siding with ColorMax® finish is covered with a patented protective film. To prevent surface damage prior to installation, do not remove this film before cutting or fastening.

## Section 5: Tools and Accessories

Some tools are better than others for cutting, drilling, and fastening fiber cement siding. Listed below are our recommendations for the best tools for use with WeatherBoards Fiber Cement siding.

### Cutting & Drilling

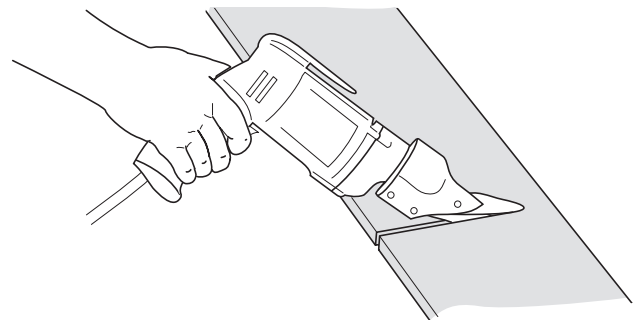

**Mechanical shears** create virtually no dust.

- ▶ **Shears**—Shears produce less dust than high-speed tools. They cut with relatively little effort, less noise, and virtually no dust. The cut is not as smooth as the cut of a polycrystalline diamond-tipped blade, but it is acceptable. Manufacturers include:

- ◆ PacTool
- ◆ DeWalt®
- ◆ Makita®
- ◆ Malco®

Fiber cement shears typically have a flat side and a bevel side; consult the shear’s user guide for proper cutting technique. When using shears, take care to avoid delamination of the product layers at the edges.

- ▶ **Guillotine Shears**—Guillotine shears can cut cleanly, without distorting the edges of the siding.

Bullet Tools™ EZ Shear™ #113	Cuts panels and trim up to 1" thick x 20" wide
Malco Fiber Cement Angle Cutter	Cuts panels up to 5/16" thick x 11" wide

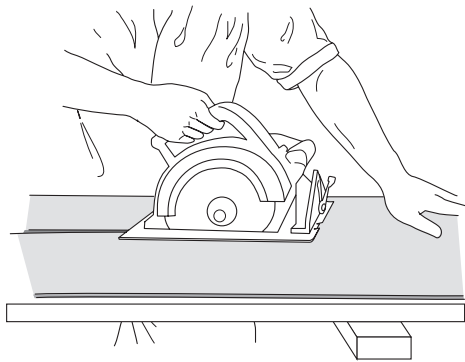

**Best Practice:** For minimal dust and a clean cut, use a circular saw equipped with a polycrystalline diamond-tipped blade.

- ▶ **Circular Saws**—Circular saws create dust and, for that reason, should be used in outdoor, well-ventilated areas. Manufacturers include:

Porter-Cable®	743K
Hitachi	C7YAH 7-1/4"
Makita®	5057KB 7-1/4"
Ridgid®	R3401 5"

- ▶ **Saw Blades**—CertainTeed recommends polycrystalline diamond-tipped blades to cut fiber cement siding because they outperform carbide-tipped blades. Fiber cement dulls carbide-tipped blades faster than polycrystalline diamond-tipped blades. You can expect to use five or more carbide-tipped blades per average residential installation, whereas polycrystalline diamond-tipped blades will perform satisfactorily for five to six residential installations.

**Exception:** Use a carbide-tipped blade to cut 5/4 and 4/4 fiber cement trim.

Manufacturers include:

Irwin® Marathon®	PCD-7-1/4 -10" -12"
Malco®	7-1/4" -10"-12"
Hitachi	7-1/4"-10"-12"
DeWalt®	7-1/4"
Tenryu	Board Pro -7-1/4"-10"-12"
Bosch	7-1/4"-10"

**NOTE:** Do not cut wood with a polycrystalline diamond-tipped blade because wood will dull the blade.

- ▶ **Miter Saw**—When equipped with a polycrystalline diamond-tipped blade, a miter saw will cut up to five pieces of fiber cement siding at a time.
- ▶ **Jig Saws**—Jig saws equipped with polycrystalline diamond-tipped blades are typically used to cut service openings, curves, radii, and other irregular shapes.
- ▶ **HEPA Filter Vacuum Attachments for Power Saws**—When cutting fiber cement, we highly recommend using power saws equipped with HEPA filter vacuum attachments. When attached directly to power tools, vacuums equipped with HEPA filters minimize the amount of respirable dust the operator is exposed to. Manufacturer’s include:
  - ◆ Fein – Turbo 2
  - ◆ Porter-Cable
  - ◆ Festool
- ▶ **Drills**—Masonry bits work best when drilling holes in fiber cement siding and trim.

## Fastening

► **Pneumatic Nailers**—Siding and roofing nailers can be used to fasten WeatherBoards Fiber Cement siding. They should not be used to fasten fiber cement trim. Use finish nail guns to install trim.

Manufacturers include:

- ◆ Max
- ◆ Hitachi
- ◆ Makita®
- ◆ Stanley Bostich®

Do not use framing nailers even if the nail is a full head because you will not be able to regulate the pressure well enough to avoid overdriving the nails.

► **Fastening to Metal**—Fiber cement siding can be attached to metal framing with any of the following tools:

- ◆ Impact Screw gun
- ◆ Aerofast Pins
- ◆ Drywall Screw gun
- ◆ Simplicity Tool Alignment Clip
- ◆ ET&F pins
- ◆ Max Tool

► **Hammer**—If you hand nail fiber cement siding, use a smooth-faced hammer. Waffle-headed hammers can mark the face of the siding.

► **Nail Placement Adapter**—

The adapter provides consistent placement of the nail one inch down from the top of the siding to the center of the nail while still allowing the depth adjustment to function properly. The adapter helps eliminate high and low nail problems and the warranty issues that can result. CertainTeed recommends using a Big Sky Adapter.

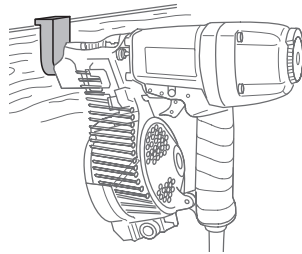

## Alignment

► Alignment tools ensure a consistent 1-1/4" overlap and allow one-person installation of fiber cement panels.

Examples include:

- ◆ PacTool Gecko Gauge™ #1
- ◆ Bear Clips
- ◆ Malco® Facing Gauge
- ◆ SoloSider Adjustable Gauge
- ◆ Simplicity Tool Alignment Clip
- ◆ Malco® Overlap Gauge

## Accessories

The right accessories can improve the overall quality of the siding project and make the job go faster. Some of the accessories CertainTeed recommends include:

- **Butt Joint Cover (H-covers)**—A joint cover is a piece of metal that fits over the joint between fiber cement siding panels. Joint covers add additional weatherproofing to the siding and increase its aesthetic appearance.
- **H-channel**—This receiving channel can be used to conceal the edges of vertical siding panels at the joint.
- **Off-stud Joiner**—Off-stud joiners are used to create a solid backing behind the joint when the joint is not located over a stud. They hold the bottom edge of the siding panel in line and provide a seamless appearing joint. Manufacturers include Simplicity Tool.

## Aluminum Moldings/Trim

Moldings and trim can define corners and transitions from one plane to another, or between dissimilar materials. Manufacturers include:

- ◆ **Easytrim Reveals** (Strongly Recommended)
- ◆ Fry Reglet
- ◆ Tamlyn
- ◆ AMF and Associates

**Note: Do not use uncoated aluminum or metal materials with fiber cement siding.**

## Backflashing

A flashing strip installed behind the butt joint of lap siding, extending 3" to the left and right of the joint and 1" over the top of the previous course of siding.

Examples include:

- Bear Skin
- Simplicity Tool Junction Flashing
- Painted Aluminum Trim Coil
- #15 felt

## Section 6: Cutting

Installing fiber cement siding requires carpentry skills and knowledge that are unique to this material. There are two key techniques to the way the material is cut and fastened. Also, good wall preparation is extremely important to a quality job, so much so that we have devoted a full section to it starting on page 27.

### Personal Protective Equipment

When fiber cement is cut or drilled, it will create dust. This dust may contain crystalline silica, which can pose a health risk. Using the recommended cutting tools and blades can greatly reduce the amount of dust generated when cutting fiber cement. To minimize dust, use cutting tools equipped with a dust collector, and never use water when cutting. Ensure adequate ventilation by working outdoors or by using mechanical ventilation to reduce potential exposure below applicable exposure limits. If ventilation is not adequate to limit exposure, wear a NIOSH-approved disposable respirator (N95) or air purifying cartridge respirator fitted with N (non-oil), P, or R series filters. Finally, always wear safety goggles and dust protection equipment when operating cutting tools.

### Cutting Tools and Blades

#### Recommended Tools and Blades

<b>Good</b>	<p>Power miter saw with polycrystalline diamond-tipped blade</p> <ul style="list-style-type: none"> <li>▶ Creates more dust than a circular saw with a polycrystalline diamond-tipped blade</li> </ul>
<b>Better</b>	<p>Circular saw with carbide-tipped blade</p> <ul style="list-style-type: none"> <li>▶ Becomes dull faster and creates more dust than polycrystalline diamond-tipped blade</li> </ul>
<b>Best</b>	<p>Circular saw with polycrystalline diamond-tipped blade</p> <ul style="list-style-type: none"> <li>▶ Creates less dust than miter saws and carbide-tipped blades</li> </ul>

### Requirements

- ▶ Cut fiber cement board face down when using a circular saw or mechanical shears. Cover the saw table with a piece of carpet or soft cover to avoid scratching the face of the siding.

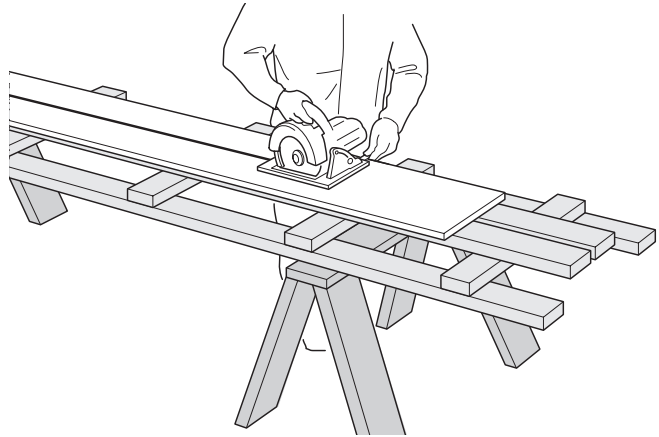

**Proper Cutting Setup**

Use good support and position the siding face down when using a circular saw or mechanical shears.

- ▶ Cut fiber cement board face up when using a chop/ miter saw.
- ▶ When cutting fiber cement, support the board along its length and near the cut.
- ▶ To avoid breakage, use extra care when you cut near the edge.

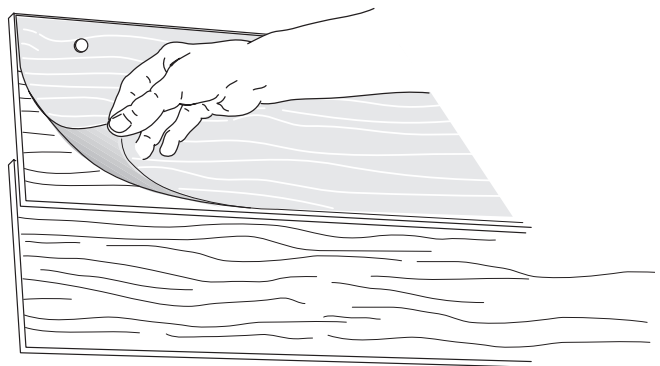

**Leave Protective Film** on Cedar Lap Siding with CertainTeed ColorMax® Finishing System until board is installed.

- ▶ Handle narrow and notched pieces carefully to avoid breakage.
- ▶ When cutting beaded siding profile, start the cut against the bead.
- ▶ When cutting CertainTeed WeatherBoards Fiber Cement Cedar Lap Siding with CertainTeed ColorMax® finish, leave the protective film in place until the siding is nailed to the substrate; then remove it before applying the next course.

**NOTE: Always re-seal all field-cut edges with 100% acrylic latex paint or primer before installing fiber cement.**



## Section 7. Fastening

Fiber Cement should be fastened to studs or solid framing a maximum of 24" on center (o.c.). In some instances, there may not be a stud or framing member available to fasten into—such as along a rake, inside or outside corners, or at a window or door opening. In these areas, the fiber cement must be fastened to a structural-rated sheathing. Refer to the “Basic Fastening Schedule” for applications in wind zones up to 110 mph (≤30 ft. high, Exposure B).

Building codes and regulations vary throughout the country. In some specific situations, fastening into other structural materials may be acceptable. Refer to local building codes and/or ICC-ES Report ESR-1668 found on [www.certainteed.com](http://www.certainteed.com) for alternative applications or wind conditions.

All fasteners must be corrosion-resistant, double hot-dipped galvanized or stainless steel. Do not use electro-galvanized nails because they corrode faster, especially in coastal areas.

**NOTE: Basic fastening schedule appears on page 26.**

### Nails

- ▶ CertainTeed recommends non-corrosive, double hot-dipped, galvanized or stainless steel siding nails. Do not use electro-galvanized nails.
- ▶ Other non-corrosive nails may be acceptable; refer to local building codes.
- ▶ Color-matched, double hot-dipped, galvanized nails for face nailing siding and trim with CertainTeed ColorMax® finish are available from Maze Nails ([www.mazenails.com](http://www.mazenails.com)).

### Screws

- ▶ Must be non-corrosive and designed for use with fiber cement.
- ▶ Screw type is determined by application and/or wall design
- ▶ Screw head diameter should be equal to or greater than 0.375".

The following suppliers manufacture screws specifically designed for use with fiber cement siding:





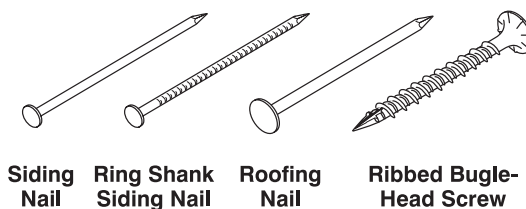
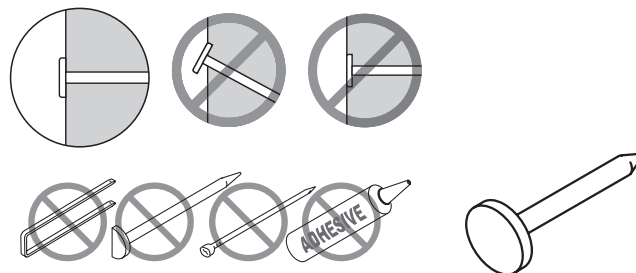

- ▶ **Grabber®:** [www.grabberman.com](http://www.grabberman.com)
- ▶ **ITW Buildex:** [www.itwbuildex.com](http://www.itwbuildex.com)
- ▶ **Prime Source®:** [www.pro-twist.com](http://www.pro-twist.com)
- ▶ **Simpson-Strong-Tie Quik Drive®:** [www.strongtie.com](http://www.strongtie.com)

**NOTE: For ICC reports, refer to [www.certainteed.com](http://www.certainteed.com)**



Siding Nail   Ring Shank Siding Nail   Roofing Nail   Ribbed Bugle-Head Screw

## Acceptable Fastening Alternatives

Screw Driver	
Phillips	
Robertson	
Drill Point/Tip	
Type 17	
Self Drilling	
Winged Self Drilling	
Screw Shape	
Flat/Counter Sunk/Bugle	

## Fastening to Structural Materials

### Fastening to Wood

The maximum stud spacing allowed is 24". Refer to local building codes for structural requirements.

Nails must penetrate a minimum of 1-1/4" into the structural framing. The minimum penetration may include the thickness of the structural sheathing (7/16" OSB or 1/2" plywood).

If you use screws, a minimum of 3/4" must penetrate the structural framing. Some screws may require more than 3/4" penetration to resist lateral loads—refer to the screw manufacturer for requirements.

You can hand nail WeatherBoards Fiber Cement. However, fiber cement is harder than wood, so be sure the nails are well set before driving them. It may be necessary to predrill the holes at the corners to prevent the edges from breaking.

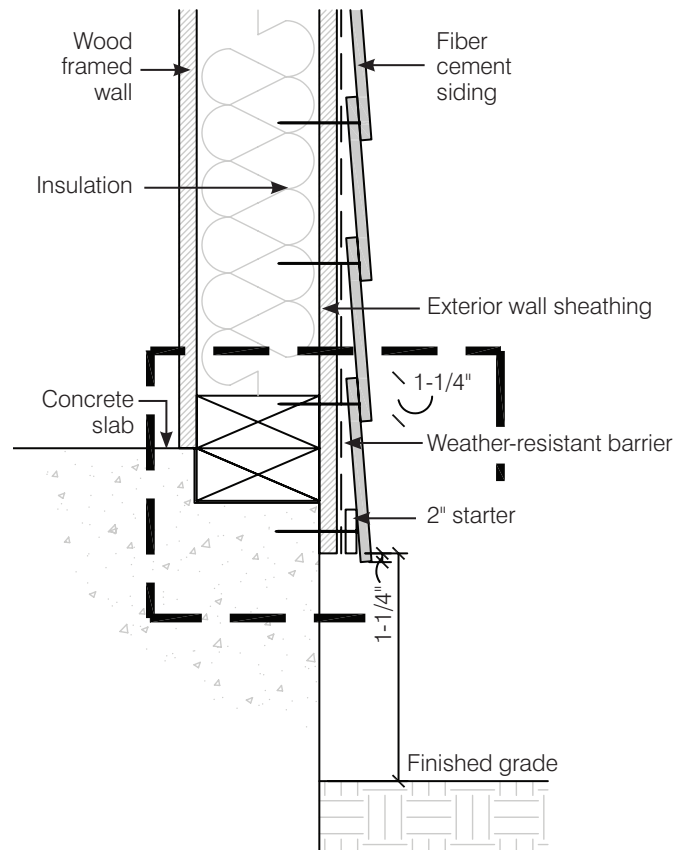

Fastening to Wood

### Fastening to Metal Framing

Fiber cement siding can be installed over metal framing.

Fiber cement must be attached to the metal framing members. Screws must penetrate into the metal framing a minimum of 1/4" or three threads.

Self-tapping, corrosive-resistant, ribbed bugle-head screws specifically designed for use with fiber cement siding are recommended.

You may also use corrosion-resistant pneumatic pins to fasten the siding to metal framing. Consult the pin manufacturer for application instructions.

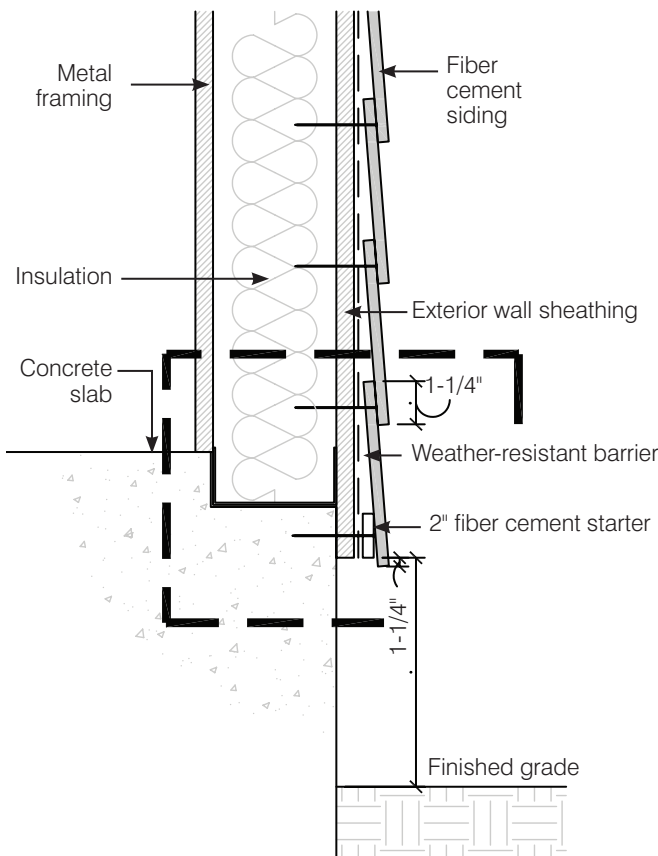

**Fastening to Metal**

### Determining Approved Heights for Installing Fiber Cement Siding

CertainTeed does not limit the height at which WeatherBoards Fiber Cement siding can be installed. Rather, the allowable height is constrained by:

- ▶ National, state, and local building codes, as adopted by the local jurisdiction
- ▶ The design windload that is specific to the project and location for the cladding
- ▶ The construction assemblies and systems for the specific project
- ▶ The allowable windload capacity of the siding product to be installed

To determine allowable heights, consult with your local code official or governing body and follow the requirements listed in ICC-ES Report ESR-1668, CCMC Evaluation Report 12987-R at [certainteed.com](http://certainteed.com)

## Fastening Requirements for Atypical Walls

### Non-vertical Walls

WeatherBoards Fiber Cement can be installed on non-vertical walls when the walls are no more than 30° off the vertical, or no less than a 60° angle, measured from the plane of the ground, and the wall is not a functional roof above occupied space. The top of the wall cannot be higher than 30' above grade. Because of different wind-load requirements, your local building code may stipulate a lower height. Use the lesser of the two heights.

1. Install an underlayment of #15 (minimum) felt or waterproofing membrane.
2. Cap the uppermost edge of the top siding course to prevent the water from getting behind the siding.
3. Flash all accessories to shed water away from the substrate.

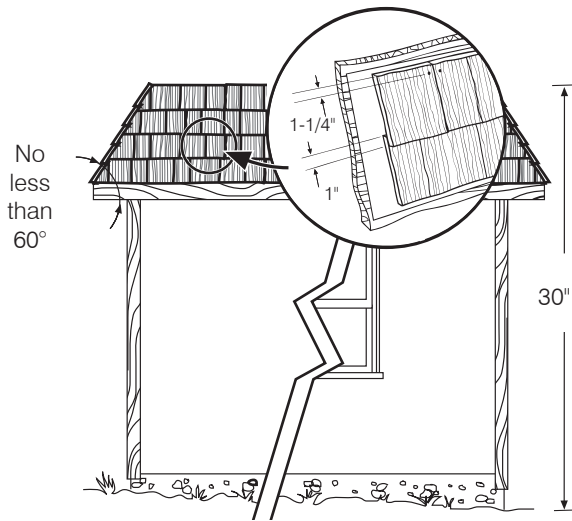

### Alternative Wall Systems

WeatherBoards Fiber Cement siding may be applied over alternative wall systems such as Structural Insulated Panels (SIP), Insulated Concrete Forms (ICF), and Rainscreen Systems. Fastening requirements for the siding depend on the specific wall system design. Fastening fiber cement onto alternative wall systems must be in accordance with local building codes. Refer to the specific wall system manufacturer for cladding recommendations.

### Structural Insulated Panels

Structural Insulated Panels (SIP) are a manufactured wall system, so follow the manufacturer’s instructions for the application of the SIP and cladding.

The siding attachment methods and their allowable windload capacities below are based on testing in accordance with ASTM E330 (wind load) and ASTM D1037 (fastener withdrawal and pull through). The SIP system must be capable of supporting the imposed loads from the siding, including dead load and wind loads.

### Fiber Cement Siding Allowable Wind Load

	Fastener	Fastening Method	Allowable Wind Pressure
Lap Siding (up to 8-1/4")	1-3/4" roofing nails, double HD galvanized; 3/8" head	Blind nailed 8" o.c.	40.44 psf; 125 mph in "B" exposures up to 30'
	1-3/4" roofing nails, double HD galvanized; 3/8" head	Blind nailed 12" o.c.	27.0 psf, 105 mph in "B" exposures up to 30'
Lap Siding (9-1/4")	1-3/4" roofing nails, double HD galvanized; 3/8" head	Blind nailed 8" o.c.	32.22 psf; 110 mph in "B" exposures up to 30'
	6d 2" siding nails; double HD galvanized	Face nailed 12" o.c.	24.4 psf; 100 mph in "B" exposures up to 30'
Vertical Siding	6d 2" siding nails; double HD galvanized	6" o.c. around edges; 12" o.c. each way in the field	18.67 psf; 85 mph in "B" exposures up to 30'



### Concrete Masonry (CMU) or Poured Concrete Walls

Consult applicable building codes before installing WeatherBoards Fiber Cement siding on CMU or a concrete wall. The CMU or concrete wall must be able to resist all loads transferred from the siding. Also, comply with the requirements listed in the most recent version of this manual. The recommended fastening methods are listed below.<sup>1</sup>

<sup>1</sup> Wall preparation recommendations for CMU and Poured Concrete Walls can be found on page 28.

#### Recommended Fasteners for CMU and Concrete Walls<sup>2</sup>

	Fastener	Fastening Method	Allowable Wind Pressure
Pressure Treated Furring (1" x 3" min.) Fastened 12" o.c.	1-1/4" roofing nails, double HD galvanized; 3/8" head	Blind nailed into furring	20.0 psf, 90 mph in "B" exposures up to 30'
Pressure Treated Furring (1" x 3" min.) Fastened 8" o.c.	1-1/4" roofing nails, double HD galvanized; 3/8" head	Blind nailed into furring	39.0 psf, 125 mph in "B" exposures up to 30'

<sup>2</sup> See page 25 for recommended fasteners to install fiber cement over furring.

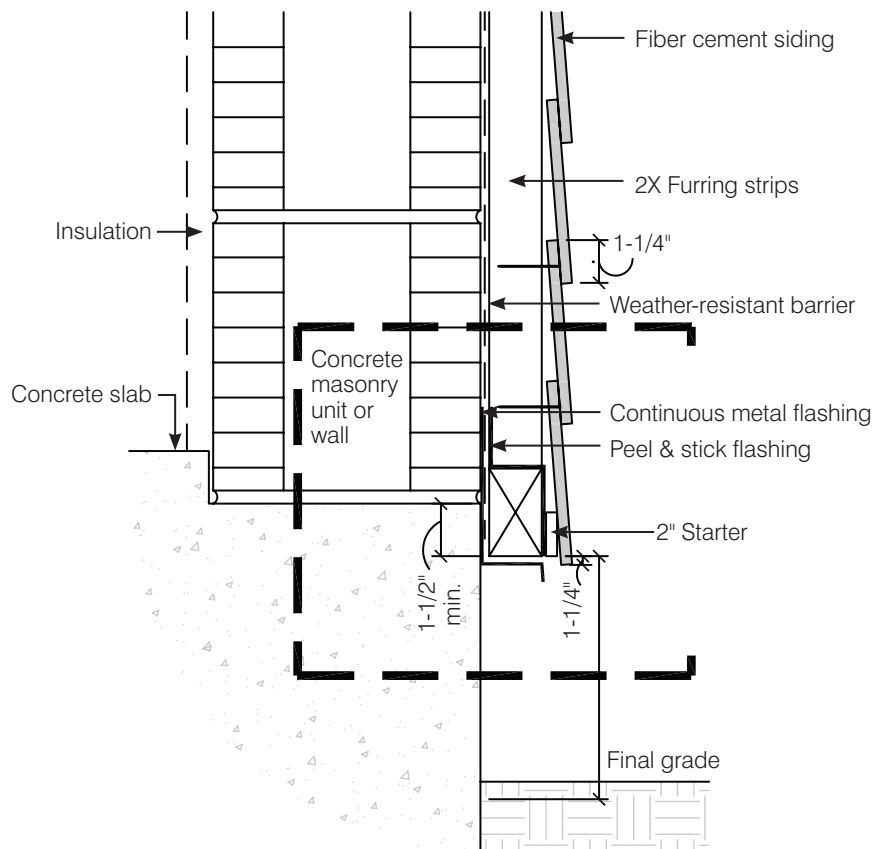

**Fastening to Concrete Masonry or Poured Concrete Walls**

## Structural Rainscreens (Steel Studs/Steel Furring Strips)

Rainscreen systems are designed to promote airflow and moisture management behind exterior cladding products. They must be designed by an architect, designer or project engineer. Non-structural lathe/furring strips are used as a spacer to establish the rainscreen and are not intended to substitute as a framing member for direct attachment of fiber cement siding.

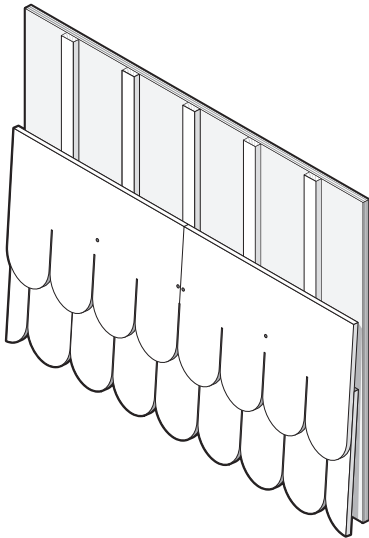

**Steel furring strips must be applied to steel framing members. Spacing between lathe/furring strips must not exceed 24".**

When incorporating CertainTeed WeatherBoards Fiber Cement siding into a rainscreen system, adhere to the following recommendations:

- ▶ The rainscreen system must be designed to ensure that all appropriate windload and anchoring requirements are met.
- ▶ Use 20 gauge (minimum) steel furring. Steel furring strips must be applied to steel framing members in such a manner that they provide equivalent load-bearing capability.
- ▶ Align all steel furring strips at framing member locations; lathe/furring strip horizontal spacing must not exceed 24".
- ▶ Base the selection of fasteners on the thickness of any non-structural material(s) between the fiber cement siding product and the framing member. Use standard fiber cement siding fasteners to attach the cladding

through the non-structural lathe/furring strips and any other non-structural materials to the structure. (Refer to the latest CertainTeed WeatherBoards Fiber Cement siding ICC-ES Evaluation Report for fastener recommendations and fastening requirements.)

- ▶ The combined thickness of non-structural materials (e.g. insulated sheathing, non-structural lathe/furring strips, etc) between steel furring and exterior cladding may not exceed 1" in thickness. (Lathe/furring strip thickness requirements may vary; check with your local code official or governing body for the building requirements in your area.)
- ▶ Adhere to all flashing, cutting and sealing requirements outlined in the most current version of this manual.

## Non-structural Rainscreens

Rainscreen systems are designed to promote airflow and moisture management behind exterior cladding products. When incorporating CertainTeed WeatherBoards Fiber Cement siding into a rainscreen system, adhere to the following recommendations and install all products in accordance with all national, state, and local building codes. Be sure to check with your local code official or governing body for the building requirements in your area.

To attach fiber cement siding over non-structural furring strips such as wood lathe/furring, treated plywood, or alternative furring strips such as Trimline™ Flow-Thru™ Furring Strips:

- ▶ Align all lathe/furring strips vertically at framing member locations. Horizontal spacing for lathe/furring strips must not exceed 24". Failure to fasten the lathe/furring strips and the siding at framing member locations may cause the siding to crack and/or wave.
- ▶ Base fastener selection on the thickness of non-structural material(s) between the fiber cement siding product and the framing member. Use standard fiber cement siding fasteners to attach the cladding through the non-structural lathe/furring strips and any other non-structural materials to the structure, and refer to the latest CertainTeed WeatherBoards Fiber Cement siding ICC-ES Evaluation Report for fastener recommendations and fastening requirements.

- ▶ The combined thickness of the non-structural materials (insulated sheathing, non-structural lathe/furring strips, etc.) between framing members and exterior cladding must not exceed 1". Requirements for the thickness of lathe/furring strip may vary, so check with your local code official or governing body for the building requirements in your area.
- ▶ For best results, apply lathe/furring strips directly over weather-resistant-barrier-clad structural sheathing that is attached to framing members.
- ▶ Adhere to all flashing, cutting, and sealing requirements outlined in the most current version of this manual.

**NOTE: Horizontal installation of furring strips may be required when installing fiber cement shake products. Using solid furring strips is discouraged in this type of installation. The ultimate responsibility for water management and diversion is the responsibility of the rainscreen system designer.**

### *Insulated Concrete Forms*

Typically, an Insulated Concrete Form (ICF) wall system relies on a plastic strip to provide the attachment point for exterior cladding. Since ICF wall systems are manufactured proprietary designs, only the ICF manufacturer can determine if the system can accommodate the applied loads created by attaching fiber cement siding.

We can provide information on the weight of the siding material and the types of fasteners used with fiber cement siding, but it is up to you to contact the ICF manufacturer to determine how best (if possible) to attach the fiber cement siding to the specific ICF system.

### **Recommended Fasteners to Install Fiber Cement Siding over Furring <sup>1</sup>**

<b>Product</b>	<b>Furring</b>	<b>Fastener</b>	<b>Fastening Method</b>
Lap Siding	Wood	1-1/4", 11 ga. roofing nail	Blind nailed into 1 x 4 furring
Vertical Siding	Wood	2" 6d siding nail	6" along the edges; 12" in the field into the furring
Lap Siding	Steel	Pins	Must penetrate furring 1/4"
		Screws	Must penetrate furring 3 full turns
Vertical Siding	Steel	Pins	Must penetrate furring 1/4"
		Screws	Must penetrate furring 3 full turns

<sup>1</sup> Wall construction must allow full penetration of the fastener through the furring.

### Fastening Requirements for Weatherboards Fiber Cement Siding

Basic Fastening Schedule <sup>1,2</sup>			Wall Framing <sup>5</sup>	
Product	Fastener <sup>3</sup>	Fastening <sup>4</sup> Method	Type	Spacing
Vertical Siding	6d siding nail (0.095 x 0.235 HD x 2" long)	6" edges, 12" in the field into framing	Wood studs 2x4 min.	16" o.c. max.
	6d siding nail (0.095 x 0.235 HD x 2" long)	6" edges, 12" in the field into furring	Wood furring 2x4 min.	16" o.c. max.
≤ 9-1/4" Lap Siding	6d siding nail (0.095 x 0.235 HD x 2" long)	Blind nailed into framing	Wood studs 2x4 min.	16" o.c. max.
	Roofing nail (0.120 x 0.375 HD x 1-3/4" long)	Blind nailed into framing	Wood studs 2x4 min.	24" o.c. max.
	Ribbed bugle-head screws <sup>6,7</sup> (#8 x 1-5/8" x 0.375" HD)	Blind nailed into framing	Metal studs 3.625" x 1.375" 16 ga.	16" o.c. max.
	Roofing nail (0.120 x 0.375 HD x 1-3/4" long)	Blind nailed into framing	Wood studs 2x4 with 7/16" OSB sheathing	8" o.c. max.
> 9-1/4" Lap Siding	8d siding nail (0.095 x 0.235 HD x 2-1/2" long)	Face nailed into framing	Wood studs 2x4 min.	24" o.c. max.
Shapes Siding	6d ring shank siding nail (0.095 x 0.235 HD x 2" long)	Blind nailed into sheathing	Wood studs 2x4 with 7/16" OSB sheathing	24" o.c. max.
Individual Shakes	Roofing nail (0.120 x 0.375 HD x 1-3/4" long)	Blind nailed into sheathing	Wood studs 2x4 with 7/16" OSB sheathing	24" o.c. max.
Soffit	6d siding nail (0.095 x 0.235 HD x 2" long)	Face nailed 12" o.c. into framing	Wood framing 2x4 min.	24" o.c. max.
Porch Ceiling	6d siding nail (0.095 x 0.235 HD x 2" long)	6" edges, 6" field into framing	Wood framing 2x4 min.	24" o.c. max.

<sup>1</sup> Wind Design: 110mph, Exposure B, ≤30ft Ht., Dp = -29.1psf (2009 IRC/IBC)

<sup>2</sup> Refer to Building Code or ESR-1668 for applicable requirements or other wind conditions.

<sup>3</sup> Fasteners must be corrosion resistant (HD Galvanized or Stainless Steel).

<sup>4</sup> 1-1/4" min. fastener penetration into framing unless indicated otherwise in these instructions.

<sup>5</sup> Wall framing, furring, and/or structural sheathing must be designed in accordance with local building codes and code compliance documentation to ensure it can withstand all applicable loads, including wind loads and dead loads of the siding.

<sup>6</sup> Wall construction must allow full penetration.

<sup>7</sup> Screws designed for fiber cement siding.

## Section 8: Wall Preparation and Sheathing

Before installing WeatherBoards™ Fiber Cement Siding, review and comply with all local building codes and regulations regarding wall construction, including the proper use of framing (24" o.c. max.), weather-resistant barriers, flashings, and other building materials and systems.

If the sheathing is thicker than 1", consult the recommendations below for installing fiber cement siding over continuous insulation systems.

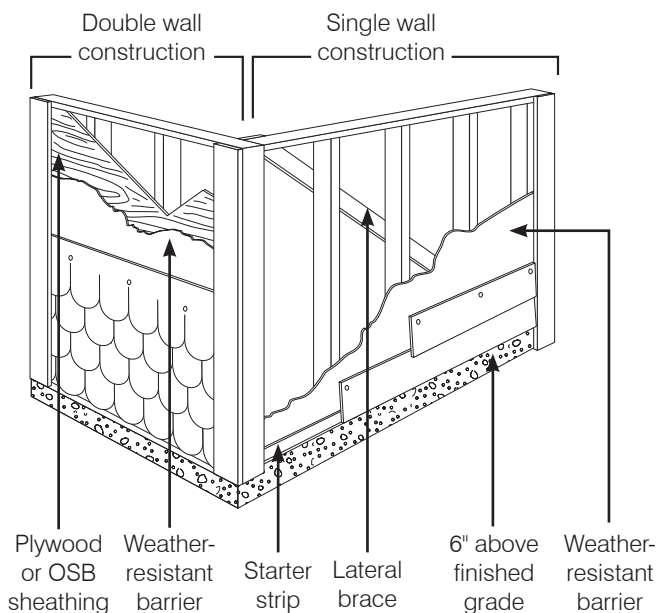

**Double and Single Wall Construction**

- ▶ Fiber cement siding should be applied over a rigid sheathing that provides a smooth, flat surface that is no more than 1" thick. Siding is an exterior cladding. It is not a complete weather-resistant barrier, so be sure to flash around all openings.
- ▶ Do not install siding over questionable wall construction. Irregularities in framing may become visible in the finished application. To minimize the effect of uneven walls, shim the wall as necessary.

- ▶ In accordance with best building practices, there should be a gap between dissimilar materials. Fiber cement should be separated from other materials such as brick, stone, wood, and metal. A 1/8" gap is recommended. Always caulk between siding and dissimilar materials.
- ▶ Siding is not a structural component of the wall. In single-wall construction, lateral bracing is required between the studs.
- ▶ Non-structural materials such as underlayments, foam board, or lathe/furring strips may not exceed 1" in thickness without re-establishing a structural nailable substrate (see below for details).

### Sheathings

#### Structural

For best results, WeatherBoards™ Fiber Cement should be installed over plywood, OSB, or comparable structural sheathing. Fiber cement siding can be installed over braced wood or steel studs in accordance with local building codes.

#### Non-structural

Installing fiber cement siding over non-structural sheathing, builder board, foam-type sheathings, and gypsum board, such as CertainTeed's GlasRoc® Sheathing, is also acceptable if the siding boards are fastened to structural framing. Non-structural sheathing thickness in excess of 1" creates a condition where WeatherBoards Fiber Cement siding products cannot be properly attached to the existing structural surface (e.g. framing members, steel studs, or structural sheathing).

The easiest way to meet the fastening requirements for CertainTeed WeatherBoards Fiber Cement siding is to install 3/4" structural sheathing over the non-structural sheathing. However, the wall assembly must be designed in such a way that the re-established structural fastening surface (e.g. OSB, plywood, lathe strips, or 1x or 2x framing lumber) is sufficient to meet the requirements of ICC-ES Evaluation Report ESR-1668.

CertainTeed does not provide instructions for wall design or assembly that specifically relates to the fastening requirements for re-establishing a structural fastening surface. However, FastenMaster® provides two documents to assist in successfully re-establishing a structural fastening system over non-structural sheathing. These reports must be used in combination with ICC-ES Evaluation Report ESR-1668 to determine attachment requirements.

- ▶ Technical Evaluation Report (TER No. 1009-01) Use of FastenMaster HeadLok™ Fasteners to Attach Cladding and/or Furring to Wood Framing through Foam Sheathing
- ▶ Technical Bulletin: Attaching Exterior Wall Covering Assemblies with Foam Sheathing to Steel Wall Framing

**NOTE: The ICC report requirements for framing type must be adhered to so as to meet the minimum requirements for fastening fiber cement siding.**

## New Construction

Fasten the sheathing securely to the studs according to local code requirements. Then apply CertaWrap™ Housewrap and Tape to the wall to establish a weather-resistant barrier. (Installation instructions for CertaWrap are available at [www.certainteed.com](http://www.certainteed.com))

## Remodeling

If you are covering old siding, there are three ways to prepare the surface of the building for the new siding.

1. Strip off the old siding and level the wall. If there is felt under the old siding, either nail it securely to the wall

or strip it off completely. If there is no solid sheathing under the siding, you will have to install it.

OR

2. Apply rigid sheathing over the old siding. Nail it securely and evenly, taking care to bridge the low spots.

OR

3. Nail vertical furring on top of the old siding. Apply rigid sheathing to the furring.

## Stucco

If you are applying siding to stucco, you will have to create an even, solid surface to attach the siding to.

1. Carefully chip the high spots off the stucco. Be careful not to crack the stucco.
2. Fasten 1" x 4" furring strips, 16" on center, over the stucco. Use ring-shanked nails or screws, and attach the fasteners to the studs according to local code requirements.

## Concrete Block (CMU) and Poured Concrete Walls

WeatherBoards Fiber Cement Lap siding may be installed over concrete masonry or poured concrete walls. When you install fiber cement over concrete walls, you must first install 1" x 3" furring strips. Furring is not mandatory over concrete block (CMU) walls, but CertainTeed recommends it. The suitability and methods of attaching exterior cladding products must comply with all applicable national, state, and local building codes. Always check with your local building inspector for the applicable codes.

### Recommended Fastening Methods for Installing Fiber Cement Lap Siding over Concrete Block (CMU) or Poured Concrete Walls

Spacing	Fastener	Fastening Method <sup>2</sup>	Allowable Wind Load <sup>1</sup>
12" o.c.	1-1/4" roofing nail, double HD galvanized with 3/8" head	Blind nailed into furring	20.0 psf, 90 mph
8" o.c.	1-1/4" roofing nail, double HD galvanized with 3/8" head	Blind nailed into furring	39.0 psf, 125 mph

<sup>1</sup> Based on "B" exposures up to 30' in accordance with 2009 IBC/IRC, Wall Zone 5, Effective Wind Area 10, Importance Factor 1.0.

<sup>2</sup> Selection of furring and attachment to the CMU or concrete wall must be in accordance with applicable building codes and be able to resist all loads transferred from the siding.

## Flashing

CertainTeed highly recommends the use of flashing to ensure a long-lasting, weather-resistant installation.

- ▶ Install CertaWrap flashing tape around all doors, windows, rake boards, and other areas where needed. Refer to installation instructions at [www.certainteed.com](http://www.certainteed.com) for more information.
- ▶ Apply drip cap, Z-flash, water diverter, and butt end/joint flashing as appropriate.
- ▶ Provide a 1/4" clearance between the bottom of WeatherBoards Fiber Cement products and the horizontal flashing. Caulk should not be used at this location.
- ▶ Weatherproof all horizontal joints on a building sided with vertical siding with non-corrosive "Z" flashing.

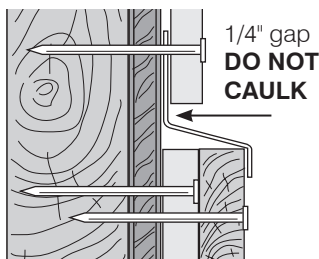

### Example of Roof Kickout

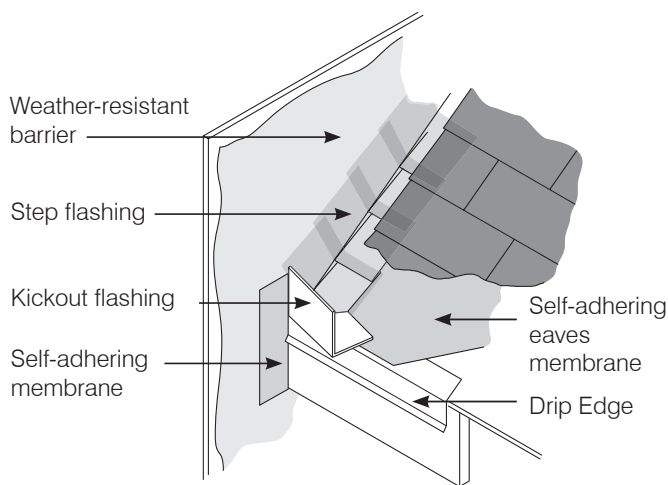

Typical flashing for a roof kickout

**NOTE: Do not caulk the bottom of the horizontal joint that is above the "Z" flashing.**

**NOTE: Do not use uncoated aluminum or metal materials with fiber cement siding.**

## CertaFlash BA™ around Windows

To install CertaFlash around a rectangular opening:

1. Make diagonal cuts in the weather-resistant barrier at the upper corners of the top (head) of the rough opening. Gently lift and tape the flap temporarily in place.
2. Cut a piece of CertaFlash™ Flex flashing for the bottom (sill) that is 12" longer than the width of the rough opening. Remove the backer from the flashing and begin applying one end to the jamb of the rough opening 6" above the sill. (NOTE: the tape will extend over the exterior edge of the jamb.) Applying even pressure to the tape with your hands, work your way down the jamb, across the sill, and up the opposite jamb, finishing 6" above the sill. Flex the overhanging tape down onto the weather-resistant barrier in weatherboards fashion, again applying even pressure to ensure adhesion.
3. Before installing the window, apply a continuous bead of sealant to the interior of the window's mounting flange. Install the window according to the manufacturer's instructions.

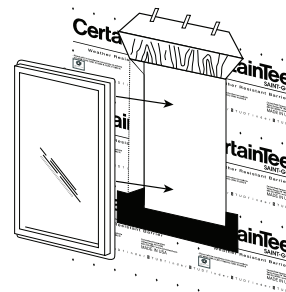
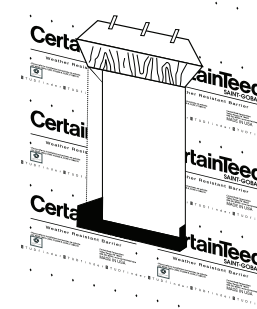
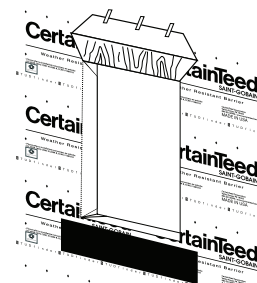
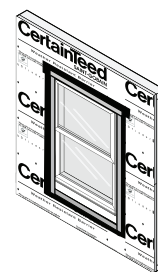

- Cut two strips of BA flashing for the sides (jambs) of the window. Jamb flashing tape should extend a minimum of 3" above the top of the jambs of the window unit and a minimum of 1" beyond the bottom flashing tape installed in step #2, covering the width of the previously installed flashing at the base. Slowly peel release paper off as you press the flashing in place. Ensure the flashing covers all nails and mounting slots on the window's mounting flange.

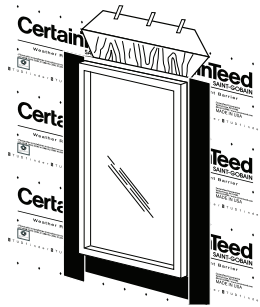

- Cut BA flashing for the top (head) of the opening so it will extend beyond both ends of the jamb flashing. Ensure the flashing covers all nails and mounting slots on the window's mounting flange.

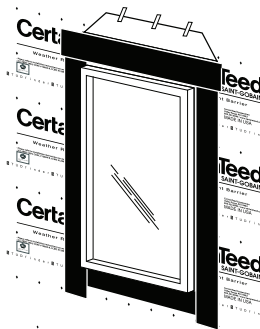

- Finally, lay weather resistant barrier over the head flashing. Apply CertaTape over both diagonal cuts.

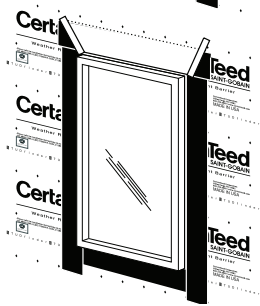

**NOTE: CertainTeed recommends 4/4" (5/4" nominal) trim for all lap and Shapes fiber cement siding, and 3/4" (4/4" nominal) trim for vertical siding and veneers.**

### Before You Begin

Before you install the trim, review and comply with all local building codes and regulations regarding wall construction, including the proper use of framing, weather-resistant barriers, flashing, and other building materials and systems. Also, review the general cutting, fastening, and wall preparation instructions in this guide. Some important reminders:

- ▶ Store trim up off the ground on a clean, flat surface in a garage or other protected area.
- ▶ Use corner protectors when banding fiber cement trim.
- ▶ Do not install wet trim.
- ▶ Lift and carry trim on the edges.
- ▶ Keep the fiber cement trim at least 6" above the finished grade and 1" above surfaces where water may collect (roofs, steps, decks, walks, and hard-surface driveways).

### Cutting

- ▶ Use a circular saw equipped with a carbide tipped blade. DO NOT use a polycrystalline diamond tip blade.
- ▶ Cut fiber cement in a well ventilated area, and use cutting tools equipped with a dust collector.
- ▶ Wear safety glasses and appropriate dust protection equipment.

**NOTE: Seal all field-cut edges with 100% acrylic latex paint. Do not paint the back of the trim.**

### Caulk

- ▶ Caulk must comply with ASTM C920 (grade NS, class 25).
- ▶ Use a high performance, paintable low-modulus elastomeric sealant applied in accordance with the caulk manufacturer's instructions.

## Section 9: Trim

For best results with WeatherBoards Fiber Cement siding, we recommend you install either WeatherBoards Fiber Cement Trim or Restoration Millwork® Exterior Trim. For installation instructions, refer to <http://www.certainteed.com/resources/rm003.pdf> or ask your building products supplier for the Restoration Millwork Installation Guide (RM003).

Other trims may also be used in conjunction with WeatherBoards Fiber Cement Siding. Refer to the trim manufacturer for compatibility and installation instructions.



### Fastening

- ▶ **Nails:** Corrosion resistant or stainless steel, 16 ga. finish nails. Nail length must allow penetration of at least 1" into solid wood.
- ▶ **Screws:** Corrosion resistant or stainless steel.

#### Fastening Schedule

Trim Size	Number of Fasteners	Spacing
4" wide or less	2	12" to 16" o.c.
5" wide or more	3	12" to 16" o.c.

- ▶ Drive the fastener perpendicular to the surface of the trim.
- ▶ Penetrate the framing at least 1".
- ▶ Always nail from one end to the other. Never nail from both ends to the middle—it will stress the trim board.
- ▶ Drive the fastener flush with the trim.
- ▶ When you install trim over lap siding, always nail through the trim and the underlying siding. Be sure to nail on the high points—or overlap—into the framing.
- ▶ Do not over drive the fasteners. When a fastener is driven below the surface of the trim, its holding power is reduced and it creates an entryway for moisture.
- ▶ Irregularities in framing may be visible in the finished application. To minimize the effect of uneven walls, shim the wall as necessary.
- ▶ If you are hand nailing, it may be necessary to predrill to help prevent the corners from breaking. Position fasteners no closer than 1" from the side edges of the trim and no closer than 2" from the end.
- ▶ For trim 4" wide or less, fasten in an alternate position to both sides of the piece, spaced no more than 12" to 16" o.c.
- ▶ For trim 4" wide or more, but less than 5" wide, apply two fasteners, one on each side of the piece, spaced no more than 12" to 16" o.c.
- ▶ Trim wider than 5" requires three fasteners.

### Paint/Primer

Use a 100% acrylic latex paint or primer applied according to the paint manufacturer's recommendations.

### Windows and Doors:

- ▶ Square or miter-cut the trim boards.
- ▶ Nail trim flush to the window or door.

### Outside Corners:

When assembling a traditional corner from two pieces, fasten the trim to the substrate, studs or blocking every 12" to 16".

### Fascia, Band and Frieze Boards, and Rakes

To install 7/16" fiber cement fascia:

- ▶ Install the fascia over a wood substrate.
- ▶ Butt the ends of the fascia and nail it every 12" to 16".
- ▶ 7/16" fascia can also be installed as band boards, frieze boards, and rakes.

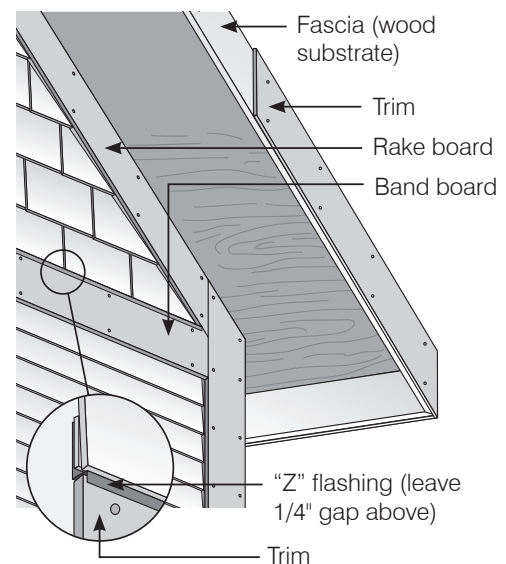

**Install trim over wood substrate.**

**Band Boards:**

- ▶ Install 7/16" fiber cement trim over furring strips with the appropriate flashing.
- ▶ Butt the ends of the trim and nail every 12" to 16".

**Rakes and Frieze Boards:**

- ▶ Butt the ends of the trim and nail through the trim substrate and siding into the framing or into a wood substrate every 12" to 16".
- ▶ Leave 1/8" between the siding and the trim when you install the siding.
- ▶ Caulk between the siding and the trim.

## Section 10: Lap Siding

Before you install the siding, review and comply with all local building codes and regulations regarding wall construction including the proper use of framing, weather-resistant barriers, flashings, and other building materials and systems.

**Before You Begin**

Review the general cutting, fastening, and wall preparation instructions in Sections 6, 7, and 8.

Remember:

- ▶ Install WeatherBoards Fiber Cement lap siding over a flat, vertical wall surface.
- ▶ Cut the siding face down with mechanical shears or a circular saw. Cut face up with a chop or miter saw. When cutting siding face down, cover the saw table with a carpet or other soft material to prevent scratching the surface of the siding.
- ▶ CertainTeed WeatherBoards Fiber Cement Cedar Lap Siding with ColorMax® finish: When cutting, leave the protective film on the siding until it is nailed to the substrate; then remove it before applying the next course.
- ▶ Beaded Board: When cutting a beaded siding profile, start the cut against the bead.

- ▶ Prime, paint or caulk all field-cut edges of siding. Do not prime or paint the back of the siding panel. Refer to instructions on butt joints and trim locations for specific requirements.
- ▶ Be sure to install all siding with the proper textured, sealed, or painted surface facing out.
- ▶ Do not over drive the fasteners. When a fastener is driven below the surface of the siding, its holding power is reduced and it creates an entryway for moisture.
- ▶ Irregularities in framing may be visible in the finished application. To minimize the effect of uneven walls, shim the wall as necessary.
- ▶ If you are hand nailing or using screws, it may be necessary to predrill corners to help prevent breakage.

**Clearances**

Fiber Cement siding should be installed to meet local building code clearance requirements between the bottom edge of the siding and adjacent finished grade. Maintain 1" minimum clearance between fiber cement products and steps, decks, and driveways and 6" above the finished grade.

Where roofs and vertical surfaces meet, flashing and counter flashing must be provided according to the roofing manufacturer's instructions. Maintain a minimum of 1" clearance between the roofing and the bottom edge of the fiber cement or other vertical surface.

**Determining the Appropriate Fastening Style—Face or Blind.**

Determine if the siding will be blind fastened or face fastened. While blind fastening makes for a more aesthetically pleasing finished look, lap siding that is wider than 9-1/4" must be face fastened. Other factors that determine fastening style include wind load, exposure, wall construction, and type of fastener.

Refer to the "Basic Fastening Schedule" on page 26 for more information or to ICC-ES-ESR-1668 report at [www.certainteed.com](http://www.certainteed.com).

## Blind Fastening

1. Make sure the panel overlaps 1-1/4"; leave a gap of 1/8" from all trim before fastening. Always caulk between the siding and the trim.
2. Place the fastener 1" from the top of the panel and no closer than 3/8" from the edge.
3. Nails must penetrate a minimum of 1-1/4" into the structural framing; screws require a minimum 3/4" penetration. Penetration may include thickness of structural rated sheathing (OSB or plywood). Some screws may require more than 3/4" penetration to resist lateral loads—refer to the screw manufacturer for requirements.
4. Do not over drive the fasteners. Seating them below the surface of the siding reduces their holding power and creates an entryway for moisture. Do not place fasteners in the center, unsupported area of the siding.
5. If you are hand nailing or using screws, it may be necessary to predrill to help prevent the corners from breaking.
6. Fasten from one end of the panel to the other.

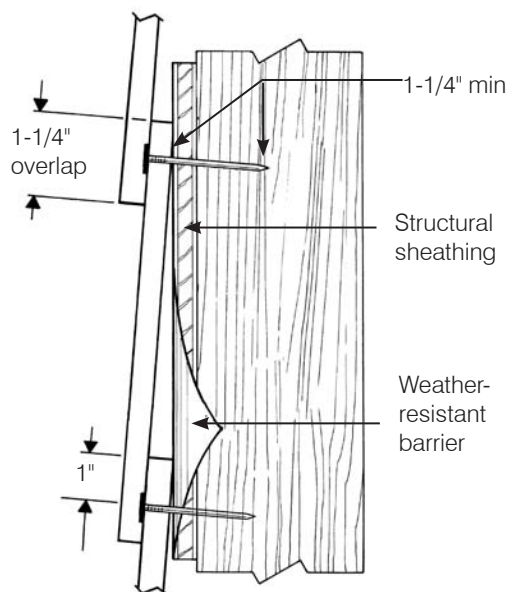

**Blind Fastening Detail**

## Face Fastening

1. Make sure the panel overlaps 1-1/4"; leave a gap of 1/8" from all trim before fastening. Always caulk between the siding and the trim.
2. Place the fastener 3/4" from the bottom of the overlapping panel. This will help ensure that the fastener penetrates both courses of siding. Place the fasteners no closer than 3/8" from the butt edge.
3. Nails must penetrate a minimum of 1-1/4" into the structural framing; screws require 3/4" penetration. Penetration may include thickness of structural rated sheathing (OSB or plywood).
4. Do not over drive the fasteners. Seating fasteners below the surface of the siding reduces their holding power and creates an entryway for moisture. Do not place fasteners in the center, unsupported area of the siding.
5. If you are hand nailing or using screws, it may be necessary to predrill to help prevent the corners from breaking.
6. Fasten from one end of the panel to the other.

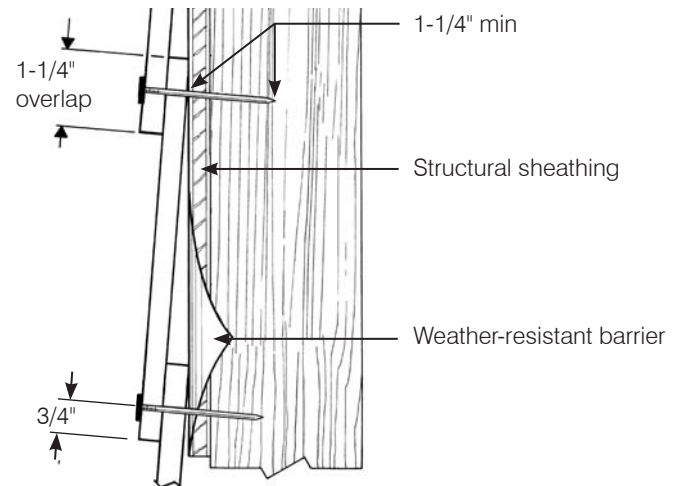

**Face Fastening Detail**

## Installation

### Mark a Starting Chalk Line

Establish a straight, level reference line to guide the positioning of the starter strip and the first course of siding.

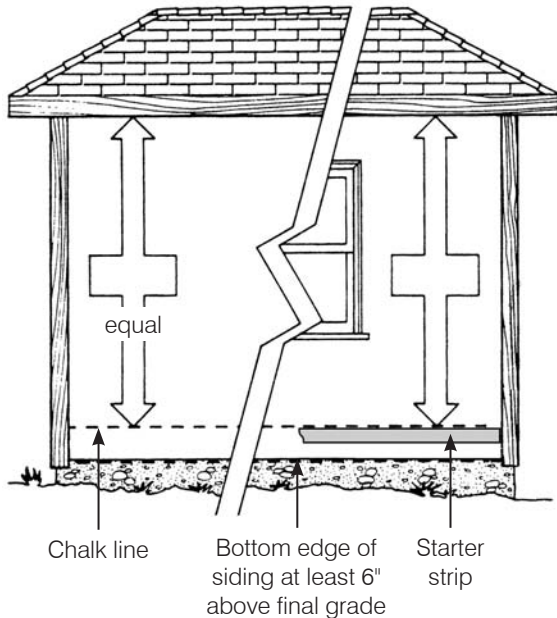

#### Establish a Chalk Line

1. Find the lowest point of the sheathing(s) and make a mark that is 1" above the lowest corner. The bottom edge of the siding will be 2-1/4" below the mark you just made. Make sure this point is high enough to ensure that the bottom edge of the siding is installed at least 6" above the finished grade or 1" above surfaces where water may collect.
2. From this mark, snap a level chalk line to the opposite end of the wall.
3. Repeat the procedure around the entire house.

### Aligning the Starter Strip

You must use a starter strip with lap siding. Except when using vinyl undersill trim as a starter, the starter strip must be a minimum of 2" wide and 1/4" to 5/16" thick.

Align the top of the starter strip with the chalk line and fasten.

### Recommended Starter Strip Options for Fiber Cement Siding

<b>Good</b>	Fiber cement siding ripped to 2" (minimum); all field-cut edges re-sealed with primer or paint
<b>Better</b>	CertainTeed Vinyl Carpentry undersill trim
<b>Best</b>	Restoration Millwork PVC skirtboard

**NOTE: Do not use treated plywood or pressure treated lattice as a starter strip. These tend to delaminate and do not remain flat.**

### Restoration Millwork® Skirtboard

Instead of a starter strip, you can also use Restoration Millwork skirtboard as a starter course for WeatherBoards Lap siding and Perfection Shingles. Skirtboard is preferable to a starter strip because it can be installed at or below grade and it provides the minimum 6" clearance requirement to the finished grade for fiber cement siding.

Fasten the skirtboard the same way you would install a trimboard:

- ▶ Make sure the skirtboard is level.
- ▶ Fasteners must penetrate a minimum of 1-1/2" through a flat, solid wood substrate into a framing member.
- ▶ Apply skirtboard over framing no greater than 16" on center. If framing members are greater than 16" on center, provide additional bracing for fastening.

**NOTE: Check local code requirements for recommended height of skirtboard above the finished grade.**

- ▶ Fastener heads should be flush with the surface of the skirtboard or slightly indented and no closer than 3/4" from the end and edges of the board.
- ▶ Use two fasteners per framing member for 6" skirtboard and three fasteners per framing member for 8" skirtboard.
- ▶ Position the first course of lap siding so that the bottom edge hangs a minimum of 1/4" over the top of the skirtboard.
- ▶ Allow 1/4" per 18' of skirtboard for expansion and contraction (1/8" at each end).
- ▶ Use scarf joints to minimize seams and allow expansion and contraction.
- ▶ Vinyl building products expand and contract as the temperature changes. You must allow for this movement when you fasten Restoration Millwork. You can minimize the movement by observing proper fastening techniques along the entire length of the skirtboard.

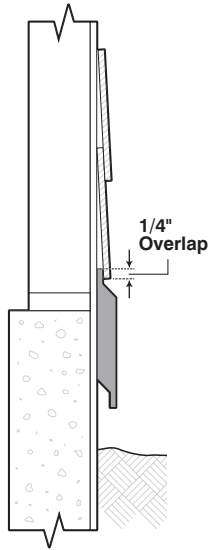

- ▶ Glue scarf joints between the pieces to help control separation caused by expansion and contraction. Gluing the joints moves the expansion and contraction out to the end.

**Installing the First Course**

- ▶ Using the starter strip or skirtboard as a guide, position the bottom edge of the first course of lap siding so that the bottom edge hangs 1/4" below the bottom of the starter strip or overlaps the skirtboard a minimum 1/4".
- ▶ Leave a 1/8" gap between the siding and the trim or other materials to allow for structural movement. Always caulk between the siding and the trim

**NOTE: When installing fiber cement siding into a J-channel or other receiving channel, ensure that all cut edges have been re-sealed with primer or paint prior to insertion; do not caulk between the siding and the channel, either before or after siding installation as this may restrict water movement around the opening. Make sure all corners are properly flashed.**

**Installing Subsequent Courses**

- ▶ Overlap all lap siding 1-1/4".
- ▶ Stagger the butt end/joints at least 32" to avoid noticeable patterns.

**32" Lap Stagger Pattern for minimum waste and staggered butt end/joints. Cut and stagger the points as indicated.**

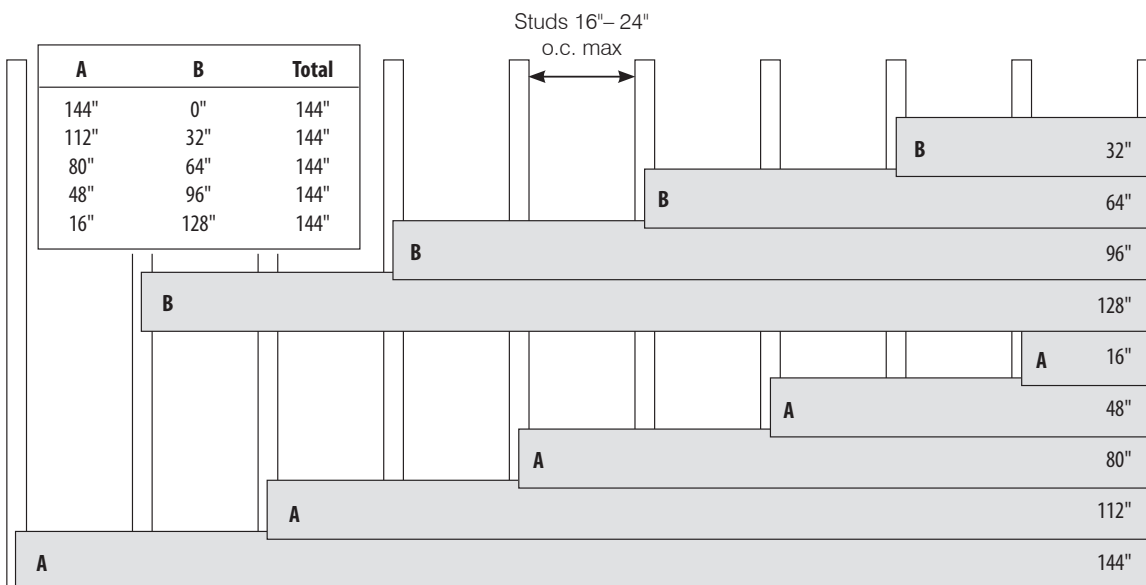

## Butt and End Joint Application

There are three ways to fasten butt and end joints:

1. Into solid framing
2. Into structural sheathing
3. With an off-stud joiner

### Butt End/Joints Fastened into Solid Framing or Structural Sheathing

Butt end/joints should be installed with factory-sealed or factory-prefinished ends butted together in moderate contact. We recommend that butt end/joints be fastened into a stud or framing member. If no stud or framing member is available, butt end/joints may be fastened into structural-rated sheathing.

When installing WeatherBoards lap siding, you must install butt joints using either backflashing, joint covers, or H-covers. Consult local code for butt joint treatment requirements in your area. Backflashing should be constructed of a durable, non-corrosive material that is compatible with fiber cement. Do not attempt to flash behind end or butt joints with housewrap—housewrap will not direct water away from the wall. Flashing size should be a minimum of 6" wide (3" to the left and right of the joint) and extend at least 1" over the top of the previous course. Examples of butt end/joint flashing materials include:

- ▶ #15 felt
- ▶ Trim coil (painted or PVC coated)
- ▶ Bear Skin™ Joint Flashing

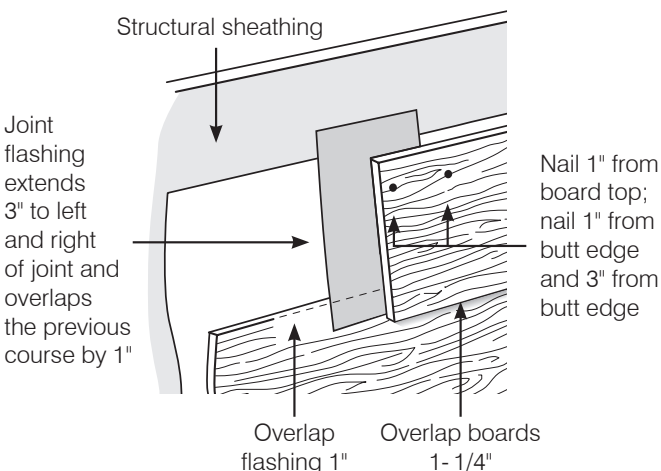

**Butt End/Joint Application:** Fastening to structural sheathing

Some flashing manufacturers, including Simplicity Tool and ProTrim, make joint flashing products that do not extend 1" over the top of the siding. They rest on top of the lap. These products are also acceptable.

If you choose to use a non-factory end at a butt joint, the side edges must be re-sealed with 100% acrylic latex paint or primer prior to installation.

**NOTE: Fiber cement siding should be fastened to framing. If no stud is available, place two fasteners 2" apart into structural rated sheathing (7/16" OSB or 1/2" plywood).**

**Fastening to Stud or Framing Member:** Place one fastener 1" below the top of the board and no closer than 3/8" from the butt edge into the stud.

**Fastening to Structural Sheathing:** Place one fastener 1" below the top of the board and 1" from the butt edge. Place another fastener 3" from the butt edge.

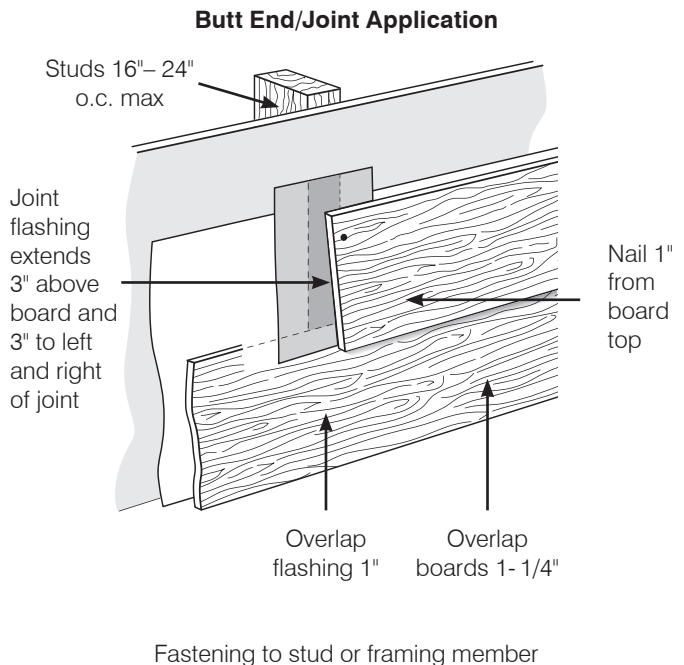

**NOTE: It is never acceptable to leave a gap of any size at a butt end/joint.**

### Butt End/Joint Covers

Lap siding butt joint covers, or H-covers, may be used for aesthetic purposes and are available in different sizes and designs. If you choose to use a joint cover, use the correct size for the siding that you are installing. Follow the specific joint cover manufacturer's instructions. Regardless of joint cover design:

- ▶ Uncoated metal joint covers are not acceptable.
- ▶ All field-cut edges at butt joints must be re-sealed with 100% acrylic latex paint or primer prior to installation.
- ▶ Flash butt and end joints with durable, non-corrosive material that is compatible with fiber cement.

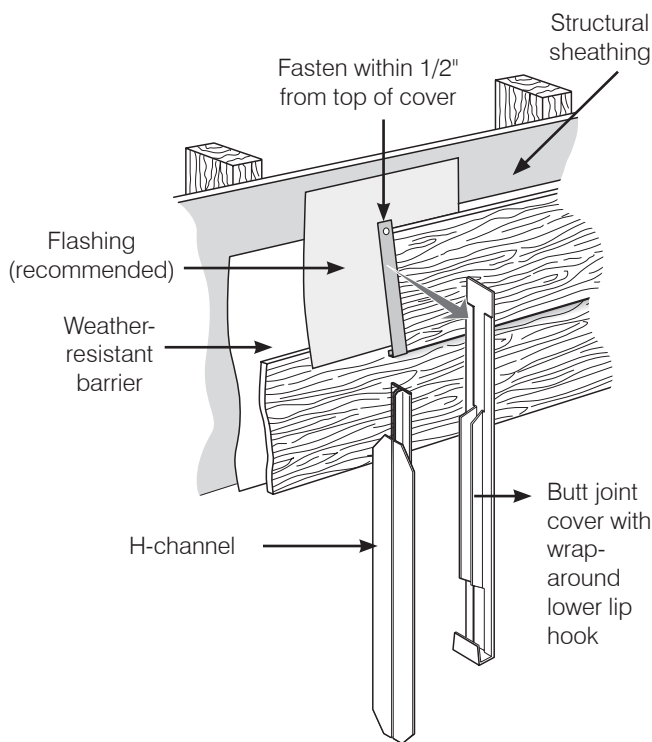

**Butt End/Joint Covers**

#### **Do not caulk fiber cement butt joints/edges.**

Applying caulk to the butt joint is ineffective because the gap is not large enough to accommodate the sealant. Also, on prefinished products, caulk may leave an unsightly looking finish. Spreading or feathering the sealant into a thin film will create a noticeably different appearance, and it can remove the needed thickness required to withstand UV exposure and joint movement.

### Joints Where Solid Framing or Structural Sheathing Are NOT PRESENT

If boards cannot be joined into solid framing or structural sheathing, you must use an off-stud joiner behind the joint. Off-stud joiners are available in different sizes. Choose the joiner that is the correct size for the siding you are installing.

1. Insert the off-stud joiner onto the butt end of the siding. Align the center of the joiner with the end of the siding.
2. Insert the edge of the next panel of siding into the other side of the joiner.
3. Make sure both butt edges of the board are either factory-sealed or sealed after a cut. Then butt the ends of boards together.

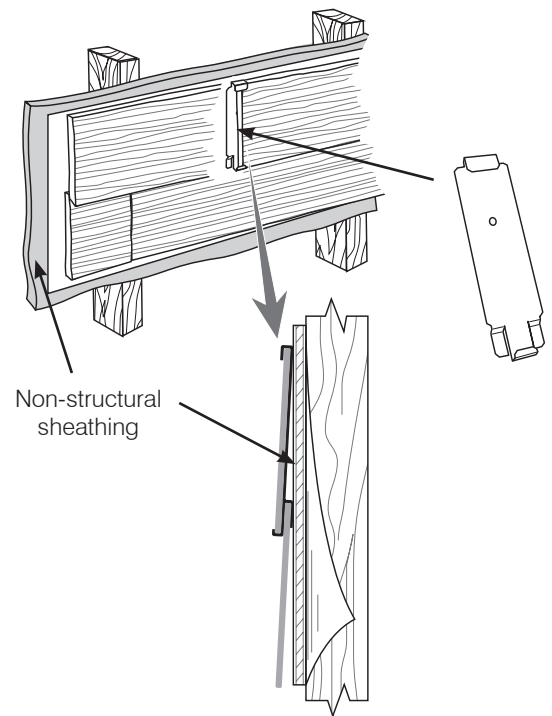

**Off-stud Joiners**

**NOTE: Do not fasten the off-stud joiner to the wall.**

## Laced (Prairie-Style) Corners

Laced or prairie-style corners, which are frequently used on single-story homes, emphasize the horizontal lines of the siding. Laced corners are created by mating each successive course of siding with its counterpart on the adjoining wall. Traditionally, this involved fitting each course of siding, marking the overlap, and removing the marked piece to make the sloped cut corresponding to the bevel of the opposite course. The end of every other piece of siding is left exposed, so the panel must be carefully sealed to prevent it from absorbing moisture. Note that accurate coursing is essential, because there's no intervening corner board to conceal any slight irregularities in alignment.

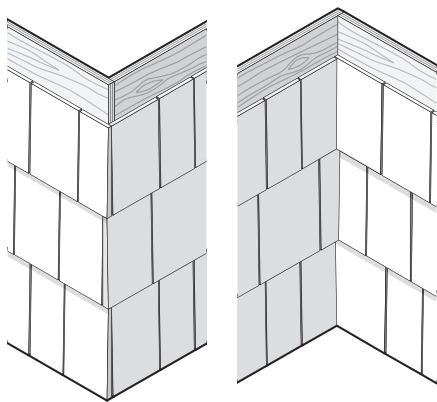

**Laced Corners**

To create a laced (or prairie-style) corner:

- ▶ Flash all corners. CertainTeed recommends installing prefinished metal flashing that extends a minimum of 10" on each side.
- ▶ Install the first board flush with the corner of the sheathing.
- ▶ Install the board on the intersecting wall so that it overlaps the width of the previous board.
- ▶ Reverse this pattern on the next course of siding.
- ▶ As you work your way up the wall, alternate the pattern, so the joint lines between the corner boards are staggered.
- ▶ Seal the exposed edges of the siding so that they do not absorb moisture.

**NOTE: Do not use prefinished product to create laced corners.**

## Section 11: Shapes Siding

Before you install the siding, review and comply with all local building codes and regulations regarding wall construction including the proper use of sheathings, framing, weather-resistant barriers, flashings and other building materials and systems.

### Before You Begin

Review the general cutting, fastening, and wall preparation instructions in the Cutting, Fastening, and Wall Preparation sections. Some important reminders:

- ▶ Cut WeatherBoards Fiber Cement Shapes face down with mechanical shears or a circular saw. To prevent marring the surface of the siding, cover the saw table with a carpet or other soft material.
- ▶ Prime, paint or caulk all field-cut edges of siding. Do not prime or paint the back of the panel. Refer to instructions on butt joints and trim locations for specific requirements.
- ▶ Be sure to install all siding with the proper textured, sealed, or painted surface facing out.
- ▶ Do not over drive the fasteners. When a fastener is driven below the surface of the siding, its holding power is reduced.
- ▶ Irregularities in framing may be visible in the finished application. To minimize the effect of uneven walls, shim the wall as necessary.
- ▶ If you are hand nailing, it may be necessary to predrill to help prevent the corners from breaking.

**NOTE: Because of the random nailing pattern, all panels except Perfection Shingles must be installed over structural rated sheathing. Fasteners may or may not hit framing/stud locations. Minimum structural sheathings are 7/8" OSB or 1/2" plywood.**



## Perfection Shingles

Perfection Shingles are installed identically to lap siding with the exception of the following:

To achieve a random pattern, Perfection Shingles must be installed with every other course rotated 180°.

1. Install the 1st course as described for lap siding.
2. When you install the 2nd course, rotate the panel 180° and fasten.
3. Install the 3rd course with the panel in the same direction as the first, and so on.

### Installation Sequence for Perfection Shingles

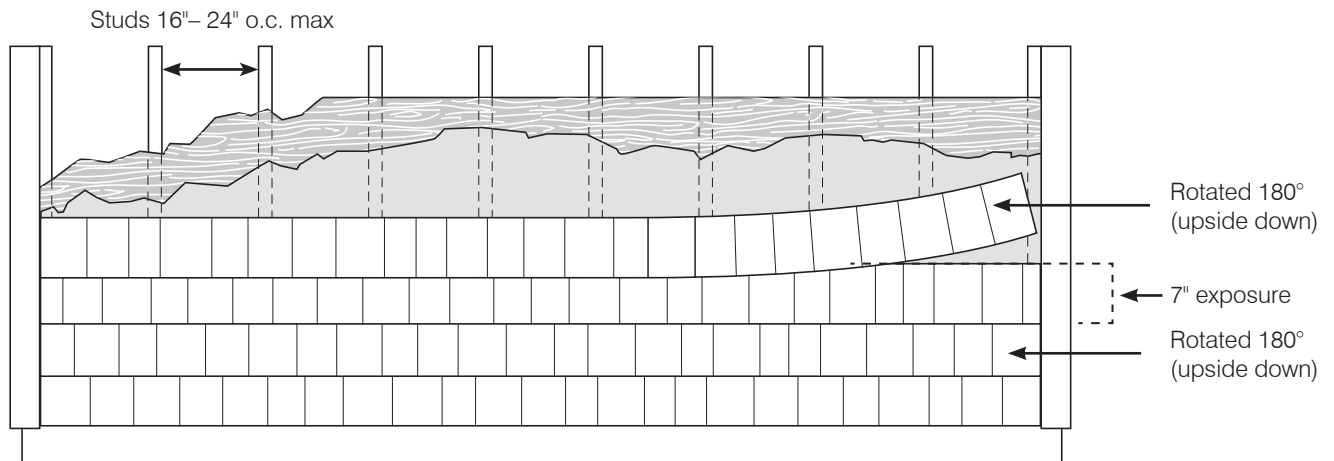

## Random Square Straight Edge and Staggered Edge

Random Square Straight Edge and Staggered Edge panels are produced in three different panels. Each of these panels has a distinct pattern and is identified by the number of V-notches cut into the side of the panel.

1. To ensure a random look, the panels must be installed in the order shown on page 40.
2. The panels should be installed over wall construction with framing spacing 16" to 24" o.c. (max) and a minimum of 7/16" OSB or 1/2" plywood sheathing.

3. Random Square Straight Edge and Staggered Edge siding must be installed only over a flat, vertical wall surface.
4. When a window or doorway breaks a course, continue the application as if the opening were not there to ensure the random look is maintained.

**NOTE: For all shapes other than Perfection Shingles, CertainTeed recommends using minimum 1" trim.**

### Identifying V-Notches

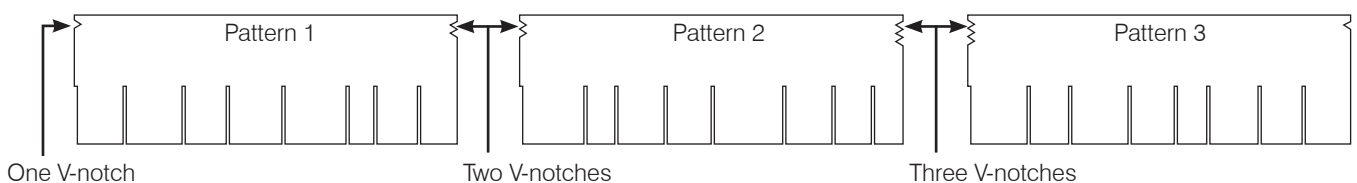

### Nailing Guide for Random Square Siding

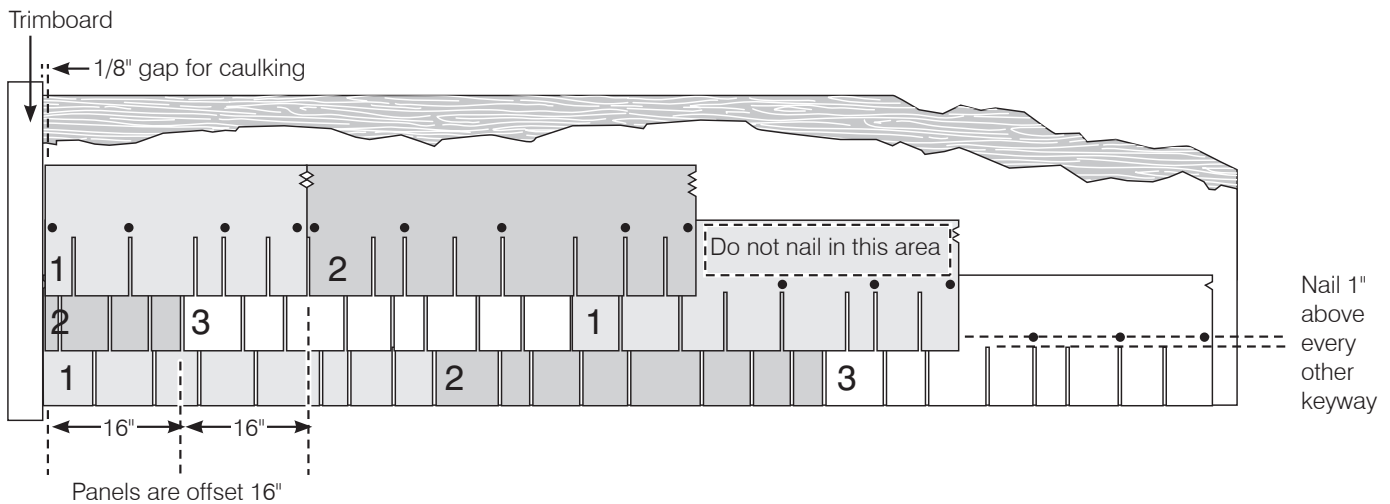

#### Starter Strip

To ensure that the keyways are fully backed by fiber cement, install the first course of Random Square Straight Edge and Staggered Edge siding over a full starter course of 8-1/4" lap siding. If you are transitioning from less than 8-1/4" lap siding to Shapes siding, use 8-1/4" lap siding as your starter course at that transition. If you are starting the wall with Random Square Straight Edge or Staggered Edge siding, place a starter strip under the 8-1/4" starter course.

You can use fiber cement, vinyl utility trim, or skirtboard as a starter strip. It must be at least 2" wide and 1/4" to 5/16" thick.

When starting the installation at ground level, establish a straight, level reference line (chalk line) to guide the positioning of the starter strip and the siding starter course (minimum 8-1/4" lap siding).

Find the lowest point of the sheathing(s) and make a mark that is 1" above the lowest corner. The bottom edge of the siding will be 2-1/4" below the mark you just made. Make sure this point is high enough to ensure that the siding is installed at least 6" above the finished grade or 1" above surfaces where water may collect.

1. From this mark, snap a level chalk line to the opposite end of the wall.
2. Repeat the procedure around the entire house.
3. Using the chalk line as a guide, attach a starter strip.

#### Starter Course

Using the starter strip as a guide, attach the starter course so that the bottom edge will project at least 1/4" below the bottom edge of the starter strip.

- ▶ Place the fastener 1" from the top of the panel and no closer than 3/8" from the edge.
- ▶ Fasteners must penetrate a minimum of 1-1/4" into the structural framing.
- ▶ Do not over drive the fasteners. Seating them below the surface of the siding reduces their holding power. Do not place fasteners in the center, unsupported area of the siding.
- ▶ If you are hand nailing, it may be necessary to predrill to help prevent the corners from breaking.
- ▶ Fasten from one end of the panel to the other.

### First Course

#### First Panel

1. Start at the left side of the wall.
2. Remove a bit of the left edge of the panels so that the entire panel butts up flush against the trim.
3. Place the first nail 1" above the top of the keyways and no closer than 3/8" from the edge of the panel. This will ensure the nails are concealed.

4. Continue nailing 1" above every other keyway. Finish the panel with a nail at the right edge.

**NOTE: Leave a 1/8" gap between the siding and the trim or other materials to allow for structural movement. Always caulk between the siding and the trim. Do not caulk between siding and any built-in receiving channels located at or around windows. Always prime or paint any cut edges that are inserted into a window J-channel.**

### Installation Sequence for Random Square Siding

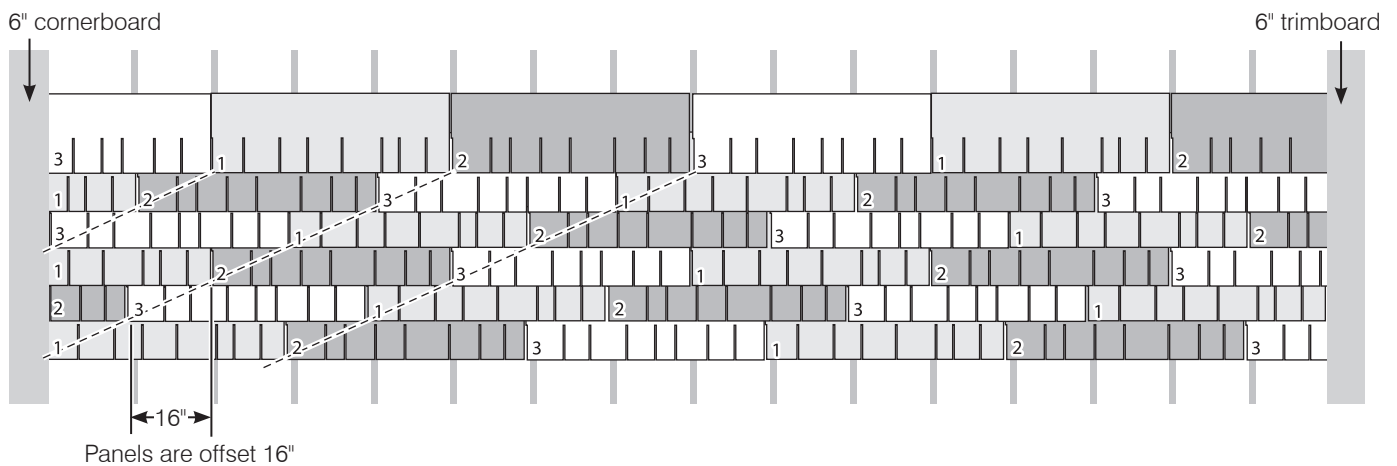

#### Second, Third and Subsequent Panels

1. Match up the corresponding panel V notches (1 to 1, 2 to 2, 3 to 3). Attach the corresponding panels to the wall in the same manner as the first panel.
2. Continue this sequence to the end of the wall.

### Second Course

To ensure a random pattern, start the second course using a #3 panel. Determine the starting point for a #3 panel by measuring 16" from the left side of the #1 panel on the first course and make a mark. Panels should be stair-stepped up the wall on 16" offsets.

1. Install the #3 panel from the mark to the right.
2. To achieve the proper exposure, measure up from the top of the panel or up from the bottom of the panel and make a mark. Align this mark with the top of the panels installed on the wall on the first course.

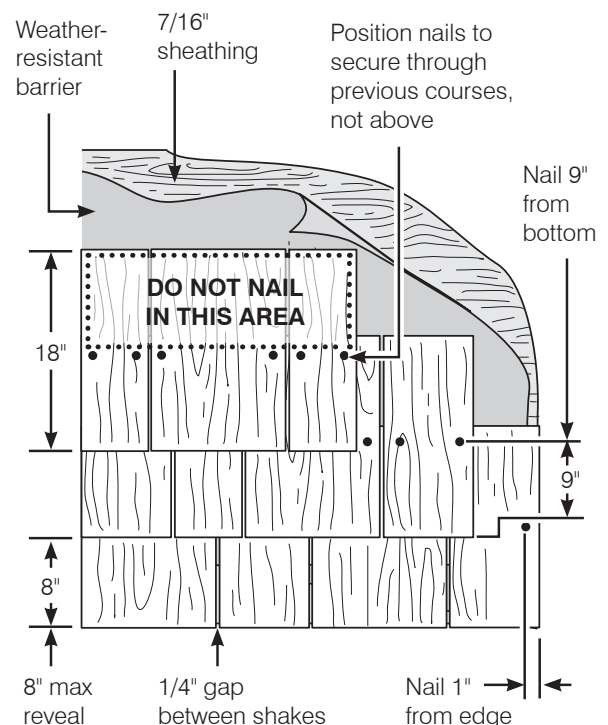

3. Refer to the following guidelines for the specific product exposures:
  - a. **Random Square Straight Edge 5" Exposure:**  
Measure up 5" from the bottom of the panel or measure up 5" from the top of the panel and make a mark on the wall.
  - b. **Random Square Straight Edge 7" Exposure:**  
Measure up 7" from the bottom of the panel or measure up 7" from the top of the panel and make a mark on the wall.
  - c. **Random Square Staggered Edge:**  
Measure up 7" from the top of the panel.
3. Install the panels by matching up the identifying V-notches (1 to 1, 2 to 2, 3 to 3) in the recommended sequence, continuing from left to right horizontally across the wall.
4. Backfill the space on the left side of the #3 panel to the cornerboard with a #2 panel (cut to fit).

**Third Course**

To continue the random pattern, start the third course with a #2 panel and follow the same procedures as the second course.

**Fourth and Subsequent Courses**

Starting with the 4th course, repeat the same installation procedure as for courses 1, 2 and 3.

1. Please refer to the illustrations on page 41 for course layout.
2. Keep in mind the sequence is: 1, 3, 2, 1, 3, 2, 1 diagonally up the wall at 16" offset.
3. Be sure to leave a 1/8" gap between the siding and the trim or other materials to allow for structural movement. Always caulk between the siding and the trim.
4. When a window or doorway breaks a course, continue the application as if the opening were not there.

**NOTE: When installing Random Square Shapes in gable ends, proceed using the same methods as described above.**

**Individual Shakes**

Before you install Individual Shakes, review and ensure compliance with all local building codes and regulations regarding the selection and proper use of sheathings, weather-resistant barriers, flashings, and other building materials and systems.

Individual Shakes must be installed over wall construction with framing spacing 16" to 24" o.c. (max.) and a minimum of 7/16" OSB or 1/2" plywood sheathing.

**Fastening Requirements**

Use double hot-dipped galvanized or stainless steel fasteners. Do not use electro-galvanized fasteners because they corrode faster, especially in coastal areas. Permissible fasteners include:

6d siding nail	0.113" x 0.281" HD x 2" long
6d roofing nail	0.120" x 0.375" HD x 1-3/4" long
ribbed bugle-head fiber cement screws	#8 -18, 1-5/8" x 0.375" HD

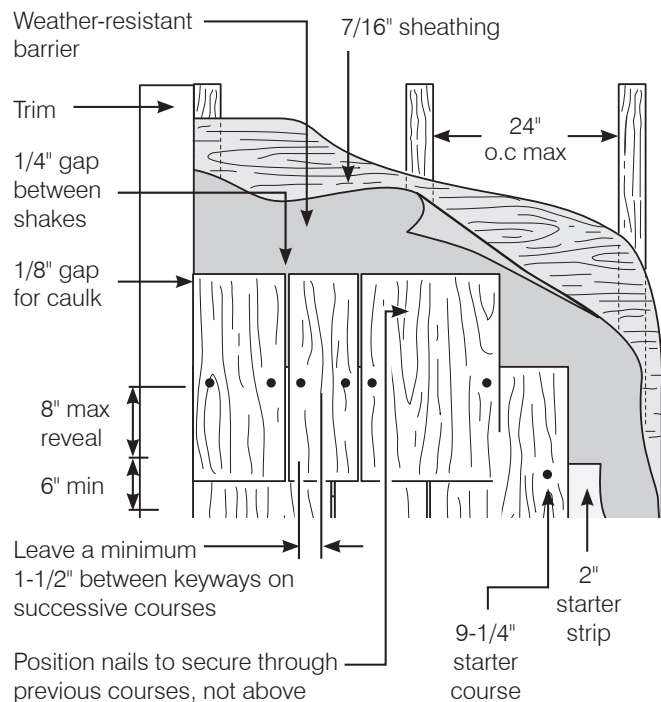

**Individual Shakes Installation**

### Starter Strip

You can use fiber cement, vinyl utility trim, or PVC skirt-board as a starter strip. It must be at least 2" wide and 1/4" to 5/16" thick. When starting installation at ground level, establish a straight, level reference line (chalk line) to guide the positioning of the starter strip and the shake starter course.

1. Find the lowest point of the sheathing and make a mark that is 1" above the lowest point. The bottom edge of the siding will be 2-1/4" below the mark you just made. Make sure this point is high enough to ensure that the shakes are installed at least 6" above the finished grade or 1" above surfaces where water may collect.
2. From this mark, snap a level chalk line to the opposite end of the wall.
3. Repeat around the entire house.
4. Using the chalk line as a guide, attach a starter strip.

### Starter Course

To ensure that the keyways are fully backed by fiber cement, install the first course of Individual Shakes over a full starter course of 9-1/4" lap siding. If you are transitioning from less than 9-1/4" lap siding to Individual Shakes, use 9-1/4" lap siding as your starter course at the transition. If you are starting the wall with Individual Shakes, place a starter strip under the starter course.

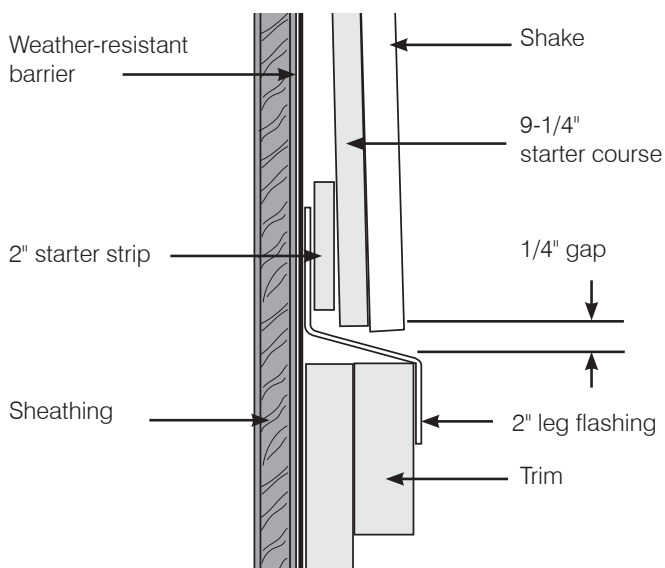

**Starter Strip "Z" Flashing Detail**

Using the starter strip as a guide, attach the starter course so that the bottom edge will project at least 1/4" below the bottom edge of the starter strip.

- ▶ Place the fastener 1" from the top of the panel and no closer than 3/8" from the edge.
- ▶ Fasteners must penetrate a minimum of 1-1/4" into the structural framing.
- ▶ Do not over drive the fasteners. Seating them below the surface of the siding reduces their holding power. Do not place fasteners in the center, unsupported area of the siding.
- ▶ If you are hand nailing, it may be necessary to predrill to help prevent the corners from breaking.
- ▶ Fasten from one end of the panel to the other.

### First Course of Individual Shakes

1. Install the first shake with the bottom edge slightly below the starter course. Be sure to maintain a 1/8" gap at all trim locations. Always caulk between the siding and the trim.
2. Place fasteners 1" from the side edges and 9" up from the bottom of the shake.
3. Continue installing shakes in a random manner, mixing the 6-1/4", 8-1/4", and 12" shake sizes. Maintain a 1/4" keyway gap between shakes.

**NOTE: Use the edge of a shake or a piece of 1/4" plywood as a jig to maintain even spacing between individual shakes.**

### Second and Subsequent Courses

1. Select and position the shake 8" up from the bottom of the previous course and such that course-to-course keyway spacing is no closer than 1-1/2".
2. Place fasteners 1" from the side edges and 9" up from the bottom of the shake. Fasteners must penetrate the top of the shakes of the previous course.
3. Continue installing shakes in a random manner, mixing the 6-1/4", 8-1/4", and 12" shake sizes to maintain the 1/4" keyway gaps and 1-1/2" minimum keyway spacing.

4. Individual Shakes are designed and installed to create a straight-edge, 8" exposure finished application. Alternative applications, such as staggered edge, can be achieved with the Individual Shakes following the basic steps noted earlier. However, the exposure should never be less than 6-1/2" and the fastening location should be kept 9" from the bottom.

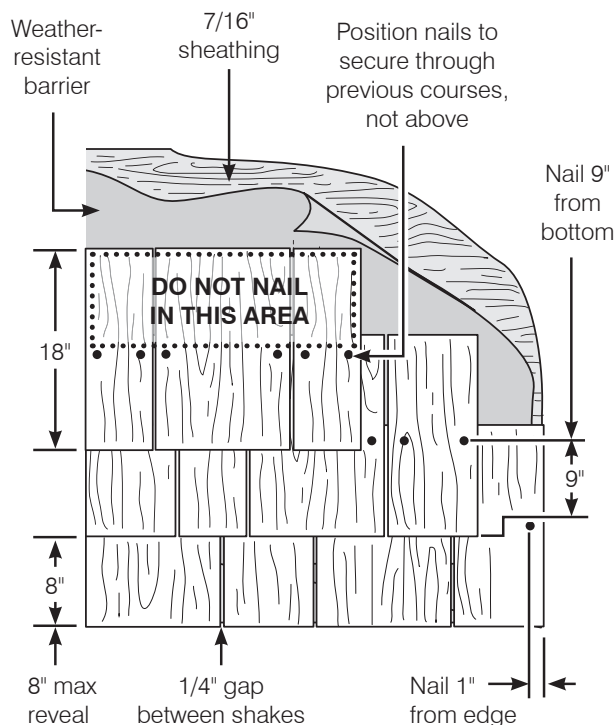

**Second Course and Subsequent Courses**

**NOTE: Fasteners must penetrate through the shakes of previous courses.**

**NOTE: Stagger must have no greater than an 8" and no less than a 6-1/2" reveal.**

**Octagons and Half-Rounds**

Octagons and Half-Rounds panels are made in a single design. There are eight 6"-wide tabs per panel. The panels must be installed over 7/16" OSB or 1/2" plywood (minimum) sheathing with framing spacing 16" to 24" o.c.

**Starter Strip**

You can use fiber cement, vinyl utility trim, or PVC skirt-board as a starter strip. It must be at least 2" wide and 1/4" to 5/16" thick.

When starting installation at ground level, establish a straight, level reference line (chalk line) to guide the positioning of the starter strip and the siding starter course (minimum 8-1/4" lap siding).

1. Find the lowest point of the sheathing(s) and make a mark that is 1" above the lowest corner. The bottom edge of the siding will be 2-1/4" below the mark you just made. Make sure this point is high enough to ensure that the siding is installed at least 6" above the finished grade or 1" above surfaces where water may collect.
2. From this mark, snap a level chalk line to the opposite end of the wall.
3. Repeat the procedure around the entire house.
4. Using the chalk line as a guide, attach a starter strip.

**Starter Course**

To ensure that the keyways are fully backed by fiber cement, install the first course of Octagons or Half-Rounds siding over a full starter course of 8-1/4" lap siding. If you are transitioning from less than 8-1/4" lap siding to Shapes siding, use 8-1/4" lap siding as your starter course at that transition. If you are starting the wall with Octagons or Half-Rounds siding, place a starter strip under the 8-1/4" starter course.

Using the starter strip as a guide, attach the starter course so that the bottom edge will project at least 1/4" below the bottom edge of the starter strip.

### Positioning and Nailing Guide for Octagons and Half-Rounds

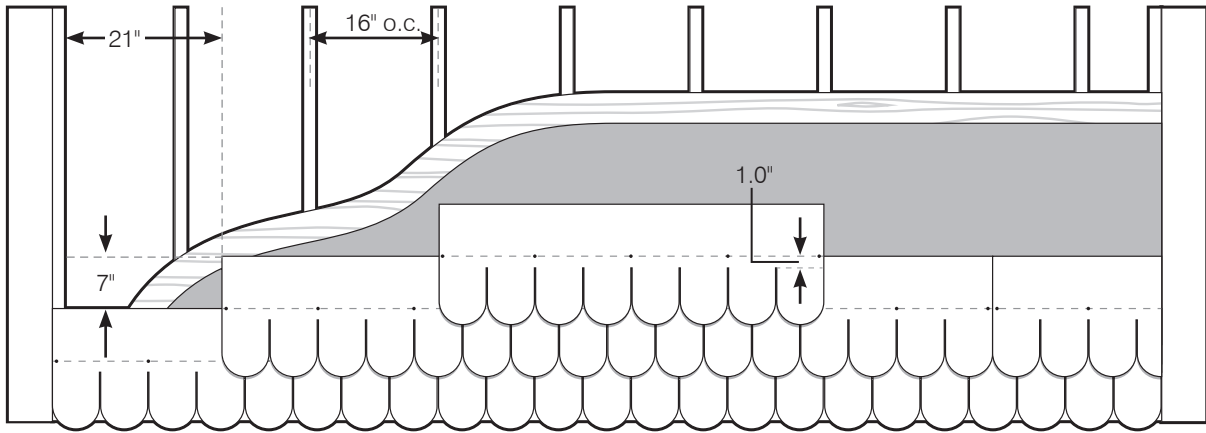

- ▶ Place the fastener 1" above the top of the keyway and no closer than 3/8" from the edge.
- ▶ Fasteners must penetrate a minimum of 1-1/4" into the structural framing.
- ▶ Do not over drive the fasteners. Seating them below the surface of the siding reduces their holding power. Do not place fasteners in the center, unsupported area of the siding.
- ▶ If you are hand nailing, it may be necessary to predrill to help prevent the corners from breaking.
- ▶ Fasten from one end of the panel to the other.

### Installing Octagons and Half-Rounds on Walls with Gable Ends

For best appearance, gable installations should end with a single Half-Round or Octagon at the peak.

1. Measure the height of the gable/wall (in inches).
2. Divide the height of the gable/wall by 7".
3. If the answer is an even number, center the first course of Half-Rounds or Octagons on a keyway.
4. If the answer is an odd number, center the first course on a Half-Round or Octagon.

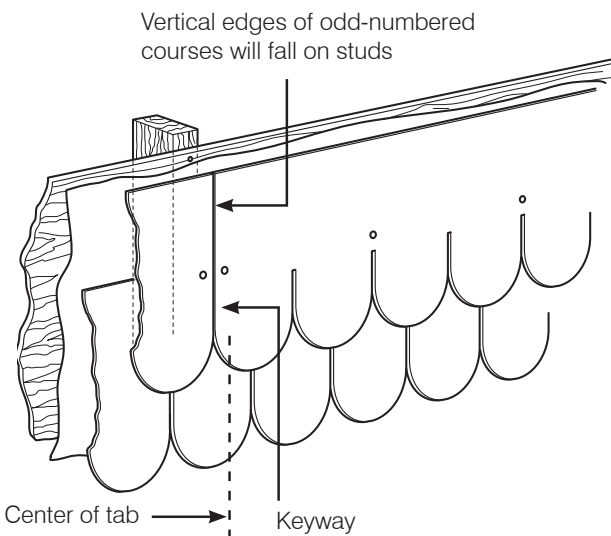

**Keyways Line Up with Center of Tab**

### First Course

1. Drop a plumb line to find the center of the gable.
2. Locate the first piece relative to the centerline of the gable/wall. The panel may be positioned anywhere along its length, as long as the keyway or shingle face is centered.

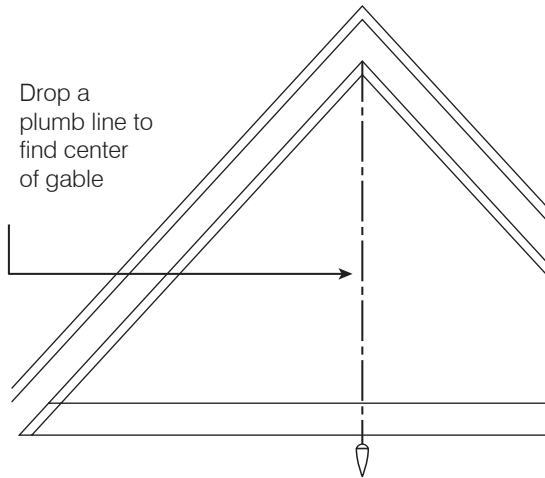

**Finding the Center of Gable**

3. Starting from the left side of the panel, place the first nail 1" above top of keyways and no closer than 3/8" from the edge of the panel. This will ensure the nails are concealed. Continue nailing 1" above every other keyway. Finish the panel with a nail at the right edge.

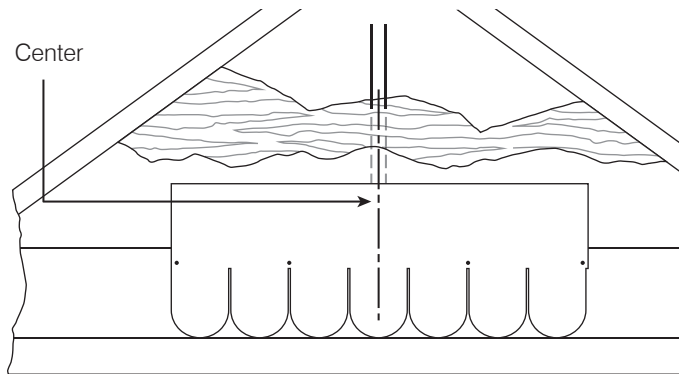

**Center the Panel on the Gable**

4. Finish installing the first course to the right and left sides, leaving 1/8" gaps between the trim and the side of the first and last panels.
5. Always caulk between the siding and the trim.

**Second Course**

1. Starting at the left side, locate the first full panel installed on the first course.
2. Offset the 2nd course 21" (3-1/2 tabs) from the first full piece. This horizontal shift will vertically align the center of each tab on the 2nd course with the keyways of the 1st course.
3. To achieve proper exposure, you can measure up 7" from the top of the panel and make a mark on the wall. Then place the top of the next course/panel on the mark that you made and nail. Or measure down 7" from the top of the next panel and make a mark on the edge of the panel. Then align the mark on the edge of the panel with the top of the installed course and nail.
4. Fasten the panel as directed for the first course.

**NOTE: Make sure the tops of the keyways are concealed by the overlapping panel before fastening the siding.**

**Subsequent Courses in Wall Areas**

1. Install the 3rd, 5th, and all other odd courses in the same horizontal position as the 1st course. Leave a 7" exposure.
2. Install the 4th, 6th, and all other even courses in the same horizontal position as the 2nd course. Leave a 7" exposure.
3. When a window or doorway breaks a course, continue the application as if the opening did not exist.



### Subsequent Courses in Gable Areas

1. Make a rake angle template for gable:
  - a. Hold a short piece of siding along the starter strip against the left edge of the gable.
  - b. Hold a second piece of siding against the trim at the rake angle of the gable.
  - c. Use this template as a guide when you cut the panels to fit the gable.

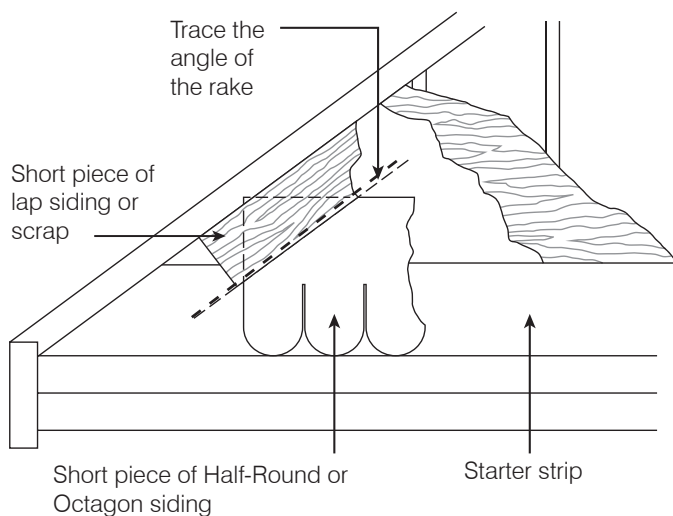

#### Tracing the Angles of the Rake

2. Run a pencil along the edge of the template piece, transferring the rake angle to the piece of siding.
3. Use the rake angle template to trim the starting panel of the subsequent courses.
4. Install the 2nd and subsequent courses according to the directions previously shown.
5. Face nail the final piece at the top of the gable and the small pieces required to fill in at the rake angle.

**NOTE: When estimating for materials, allow for a much higher scrap rate on gables than for a straight wall.**

## Section 12: Vertical Siding

Before you install the siding, review and comply with all local building codes and regulations regarding wall construction including the proper use of sheathings, framing, weather-resistant barriers, flashings, and other building materials and systems.

### Before You Begin

Review the general cutting, fastening, and wall preparation instructions in the Cutting, Fastening, and Wall Preparation sections (pages 18–29).

Some important reminders:

- ▶ Cut WeatherBoards Fiber Cement siding face down with mechanical shears or a circular saw. Cover the saw table with carpet or another soft material to avoid marring the surface of the siding.
- ▶ Prime, paint or caulk all field-cut edges of siding. Do not prime or paint the back of the siding panel. Refer to instructions on butt joints and trim locations for specific requirements.
- ▶ Be sure to install all siding with the proper textured, sealed, or painted surface facing out.
- ▶ Do not over drive the fasteners. When a fastener is driven below the surface of the siding, its holding power is reduced.
- ▶ Irregularities in framing may be visible in the finished application. To minimize the effect of uneven walls, shim the wall as necessary.
- ▶ If you are hand nailing, it may be necessary to predrill the panel to help prevent the corners from breaking.

- ▶ WeatherBoards Fiber Cement Vertical siding (panels) may be installed only over a flat, vertical wall surface.
- ▶ All edges of vertical panels must be backed by framing or solid blocking for attachment.
- ▶ Vertical panels can be hung horizontally providing the fastening schedule and flashing are followed.

**NOTE: Do not use vertical siding as soffit. Fiber cement siding is heavier than vinyl siding and can become a safety hazard if it is used overhead.**

**NOTE: See page 26 for recommended fasteners for Fiber Cement Vertical siding.**

### *Mark a Starting Chalk Line*

Establish a straight, level reference line to guide the positioning of the panel.

1. Find the lowest point of the sheathing(s) and make a mark that is 1" above the lowest corner. Make sure this point is high enough to ensure that the siding is installed at least 6" above the finished grade or 1" above surfaces where water may collect.
2. From this mark, snap a level chalk line to the opposite end of the wall.
3. Repeat the procedure around the entire house.

**NOTE: Do not install a starter strip or skirtboard.**

### *Aluminum Trim Systems*

In recent years the use of WeatherBoards Fiber Cement siding in conjunction with third-party reveal trim systems (such as Easytrim Reveals) has been increasing, especially in light commercial construction. These trim systems provide a unique aesthetic appearance to projects, providing clean, visually attractive surfaces with crisp horizontal and vertical panel transitions.

Follow all the instructions for the third-party reveal system, as long as these instructions do not reduce the performance of CertainTeed WeatherBoards Fiber Cement siding. Also, ensure that the installation of the reveal system does not in any way negatively affect the performance of the WeatherBoards Fiber Cement siding, as this may void the product warranty.

CertainTeed has reviewed the application of our products with the following trim reveal systems:

1. Easy Trim Reveals (highly recommended); [www.easytrimreveals.com](http://www.easytrimreveals.com); 877-973-8746
  2. Tamlyn; [www.tamlyn.com](http://www.tamlyn.com); 281-499-9604
  3. Fry Reglet; [www.fryreglet.com](http://www.fryreglet.com); 800-237-9773
- ▶ Establishing a structural fastening surface sufficient to meet the requirements outlined in this manual is the responsibility of the property owner, architect/designer, general contractor and/or installer.
  - ▶ Install all products in compliance with all national, state, and local building codes. Be sure to check with your local code official or governing body for the building requirements in your area.
  - ▶ Design the wall assembly to ensure that all appropriate windload and anchoring requirements are met. Consult the latest version of the ICC-ES Evaluation Report ESR-1668 for guidance on approved fasteners.
  - ▶ The installation must meet all the installation requirements listed in the most recent version of this manual.

### **Installing the Panels**

1. Use the chalk line as a guide.
2. Leave a 1/8" gap between the siding and the trim to allow for structural movement. Always caulk between the siding and the trim.
3. Fasten the siding at all stud locations.
4. Do not fasten closer than 2" from the corners in either direction.
5. Place fasteners no closer than 3/8" from edge.

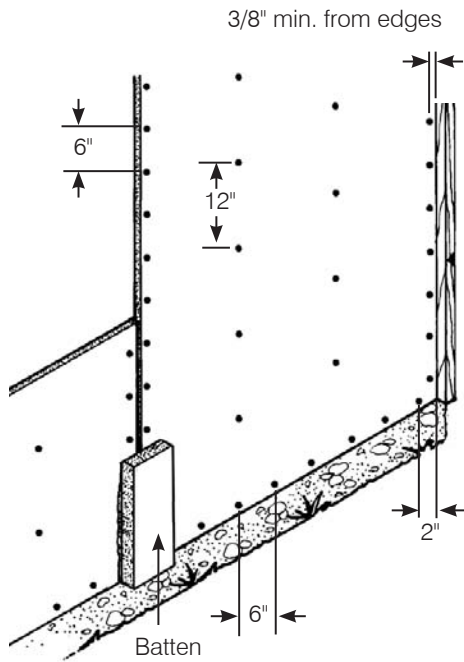

**Fastening Vertical Siding**

6. Space fasteners a maximum of 6" o.c. on all edges and 12" o.c. at intermediate framing members. Refer to ICC-ES ESR-1668 for specific fastening requirements.
7. Paint all field-cut edges.
8. Butt all vertical panel joints together. Do not caulk vertical joints.

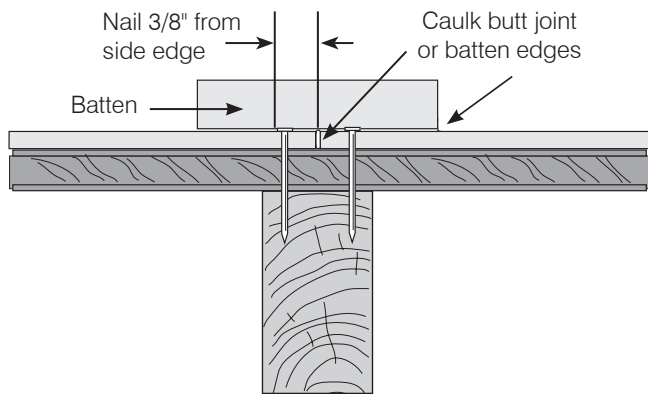

**Vertical Butted Panel Joint**

9. Install "Z" flashing and leave a 1/4" gap between horizontal panels. Do not caulk horizontal joints.

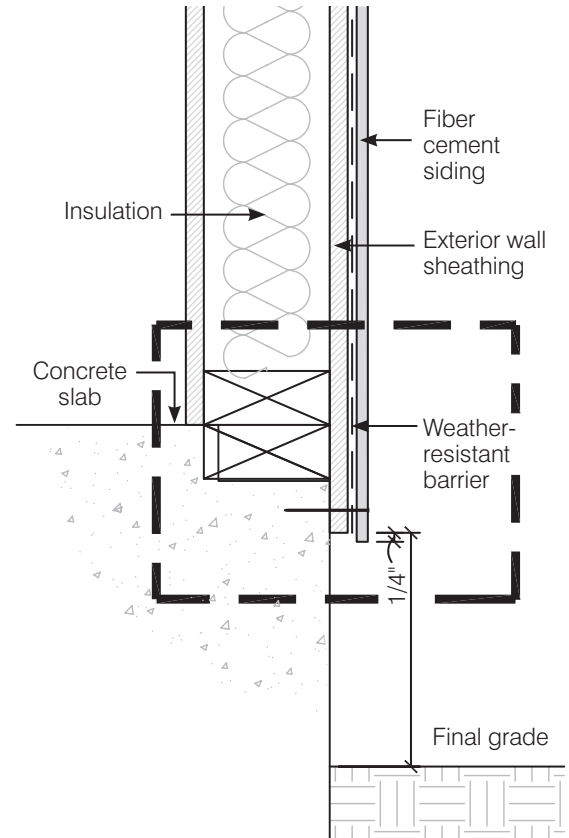

**Attaching Vertical Siding to Wood**

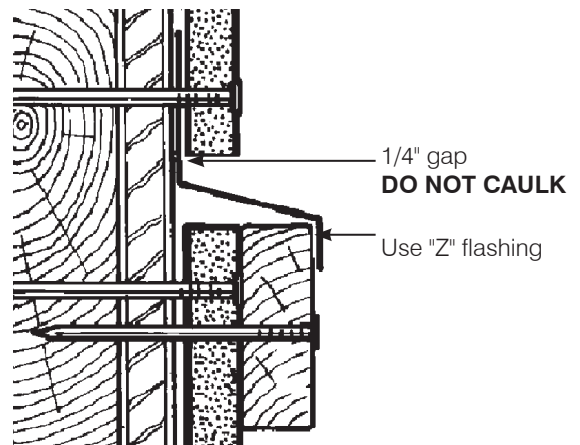

**Panel Stacking Detail**

### Board and Batten Application

WeatherBoards Fiber Cement siding can also be applied in a board and batten style. You can use wood, fiber cement, composite lumber, or cellular PVC as battens. If you install battens cut from fiber cement, paint or stain the cut edges.

To install fiber cement battens:

- ▶ Paint or stain cut edges.
- ▶ Use double dipped HD corrosion resistant nails (min. 0.113" ga, 9/32" head).
- ▶ Ensure that nails penetrate through the siding and at least 1" into solid wood.
- ▶ Position fasteners no closer than 1" from the sides of the batten and no closer than 2" from the end.
- ▶ For battens 3-1/2" wide or less, fasten on alternate sides of the batten, spaced no more than 24" o.c.
- ▶ For battens 4" wide or more, apply two fasteners, one on each side of the batten, spaced no more than 16" o.c.
- ▶ Apply caulk either at the butt joint or at both batten edges. Caulking the butt joint increases aesthetics while reducing potential long-term maintenance.

#### Board and Batten Joint

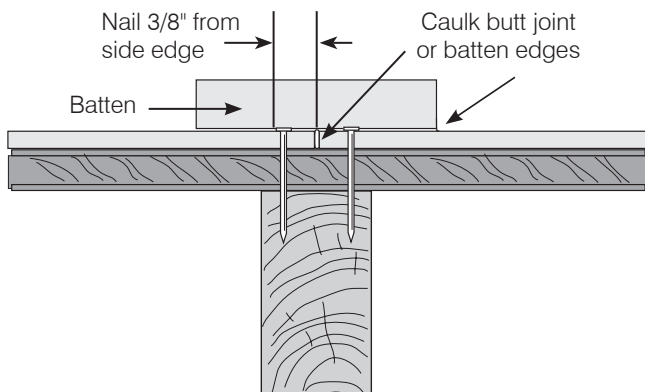

**NOTE: DO NOT seal the back of fiber cement battens.**

**NOTE: Vertical panels can be hung horizontally provided you flash the joints and follow the fastening schedule.**

## Section 13: Soffit

Before you install fiber cement soffit, review and comply with all local building codes and regulations regarding wall construction, including the proper use of sheathings, framing, weather-resistant barriers, flashings, and other building materials and systems.

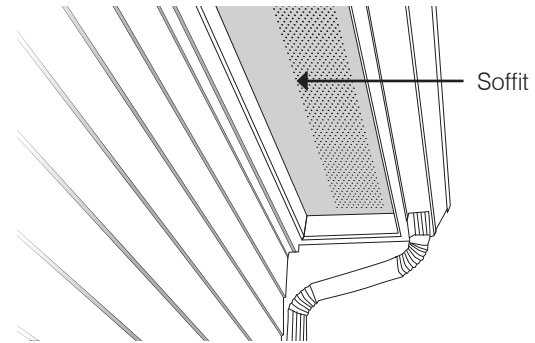

**NOTE: Do not use vertical siding as soffit—it is too heavy.**

### Before You Begin

Review the general cutting, fastening, and wall preparation instructions in the Cutting, Fastening, and Wall Preparation sections (pages 18–29).

Remember:

- ▶ Cut fiber cement soffit face down with mechanical shears or a circular saw. Cover the saw table with carpet or another soft material to avoid marring the surface of the soffit.
- ▶ Prime or paint all field-cut edges of fiber cement soffit. Do not prime or paint the back of the soffit panel. Refer to instructions on butt joints and trim locations for specific requirements.
- ▶ Be sure to install all soffit with the proper textured, sealed, or painted surface facing out.
- ▶ Do not over drive the fasteners. When a fastener is driven below the surface of the soffit, its holding power is reduced.
- ▶ Irregularities in framing may be visible in the finished application. To minimize the effect of uneven walls, shim the wall as necessary.
- ▶ If you are hand nailing, it may be necessary to predrill to help prevent the corners from breaking.

## Ventilation

Proper attic ventilation is important for any home. The 2009 International Building Code (IBC) Section 1203 Ventilation furnishes a basic guide for determining proper ventilation for any home. The information provided here may under certain circumstances not result in enough ventilation. Therefore, the calculation provided should be used only as a guide.

The IBC guideline requires that any attic or space between the top floor, ceiling, and roof must be ventilated. It requires one square foot of ventilation area for every 300 square feet of attic space, provided at least 50% of the required ventilating area has already been provided by gable and vents or ridge vents.

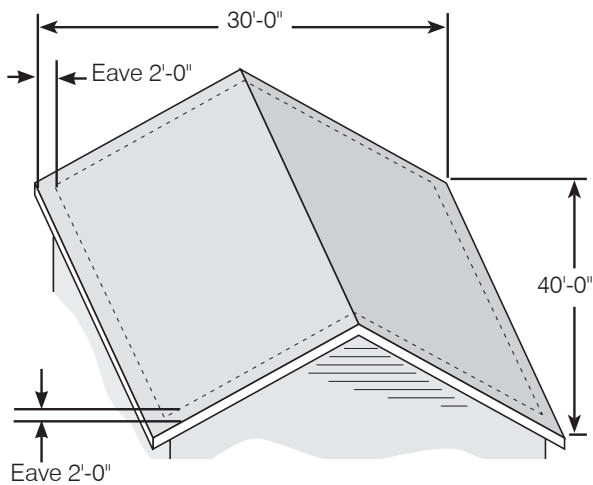

**Total Attic Area Calculation**

## Determining Soffit Ventilation (Example)

1. Determine the local code requirement for total attic ventilation:
  - ◆ 1:300 requires 1 sq. ft. of ventilation for every 300 sq. ft. of attic space.
2. Determine the total area of the attic (sq. ft.) to be ventilated (see illustration):
  - ◆ 40 ft. x 30 ft. = 1,200 sq. ft.
3. Total free area of ventilation required for the attic:
  - ◆ 1,200 sq. ft. /300 = 4.0 sq. ft.
4. Convert square feet into square inches (sq. in.):
  - ◆ 4.0 sq. ft. x 144 = 576 sq. in.
5. Factor in the location of vents:
  - ◆ 50% at ridge, roof vent or gable vent = 576 x .50 = 288 sq. in.
  - ◆ 50% at soffit/eave = 576 x .50 = 288 sq. in.
6. Determine the total soffit ventilation area required:
  - ◆ Area of the soffit available for ventilation = 80 lineal feet.
  - ◆ Ventilation area required per lineal foot of soffit = 288 sq. in. / 80 lin. ft. = 3.6 sq. in. / lin. ft.
7. Determine the amount of vented soffit required. The NFA information for CertainTeed products is available at [certainteed.com/resources/soffitspecsheet.pdf](http://certainteed.com/resources/soffitspecsheet.pdf)
8. Divide the required net free determined for the eave locations by the net free area of the soffit product.
9. Install the required amount of vented soffit accordingly.

## Installation

- WeatherBoards Fiber Cement soffit should be applied to structural framing members spaced no more than 24" o.c. with the longest dimension perpendicular to the framing.

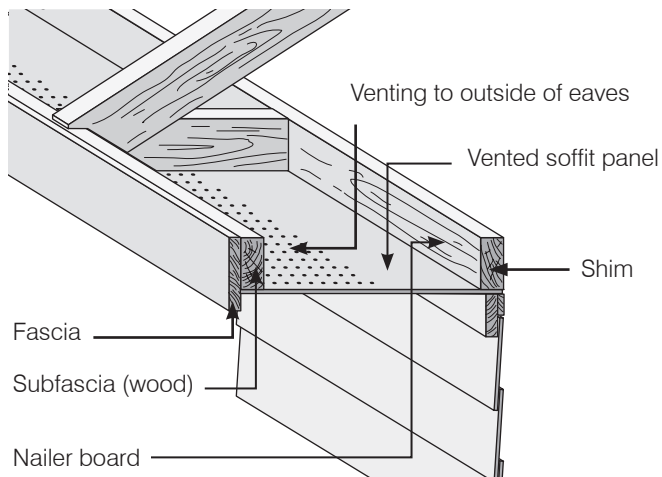

### Vent Soffit to Outside of Eaves

- Nail a 2"x 2" (minimum) nailer board along the wall, with the bottom edge of the nailer board level with the bottom edge of the fascia.
- At every butt joint of the soffit, back up the joint with 2x framing going from the fascia back to the wall. If the soffit corners are going to be mitered, nail 2x blocking from the corner of the fascia to the corner of the wall.
- If you are going to use H-channel at the mitered corners, nail the H-channel to the 2x blocking and slide the cut soffit into it. Cut the soffit 1/8" shorter than the H-channel to allow for expansion and contraction.

## Installation

- Cut WeatherBoards Fiber Cement soffit panels face down with mechanical shears or a circular saw.
- Prime or paint the cut edges before installing the soffit. Do not prime or paint the back of the soffit.
- Use double hot-dipped galvanized or stainless steel 6d or 8d nails (1/4" head minimum).
- Fasten the soffit 3/4" from the side edge, 3/8" from the butt end, and 2" from the corner. Space the fasteners every 12" along both the front and back edge. The butt ends should be in contact, fastened at corresponding ends, and supported by framing.

## Section 14: Porch Ceiling Panels

WeatherBoards Porch Ceiling panels are specifically designed to be used in porch and/or ceiling applications. The panel size is 1/4" x 4' x 8'. Before you install the Porch Ceiling Panels, review and comply with all local building codes and regulations regarding wall construction including the proper use of sheathings, framing, weather-resistant barriers, flashings, and other building materials and systems.

### Before You Begin

Review the general cutting, fastening, and wall preparation instructions in the Cutting, Fastening, and Wall Preparation sections.

Remember:

- ▶ Cut WeatherBoards Fiber Cement Porch Ceiling panels face down with mechanical shears or a circular saw. Cover the saw table with carpet or another soft material to avoid marring the surface of the panel.
- ▶ Prime, paint, or caulk all field-cut edges. Do not prime or paint the back of the panel. Refer to instructions on butt joints and trim locations for specific requirements.
- ▶ Be sure to install all panels with the proper textured, sealed, or painted surface facing out.
- ▶ Do not over drive the fasteners. When a fastener is driven below the surface of the panel, its holding power is reduced.
- ▶ Irregularities in framing may be visible in the finished application. To minimize the effect of uneven walls, shim the wall as necessary.
- ▶ If you are hand nailing, it may be necessary to predrill the panel to help prevent the corners from breaking.
- ▶ A double stud at panel joints is recommended for easier installation.

**Preparation**

- ▶ Porch Ceiling Panels must be installed over solid wood or steel framing spaced no more than 24" o.c. Additional framing may be required for proper fastening. Be sure all edges are supported by framing.

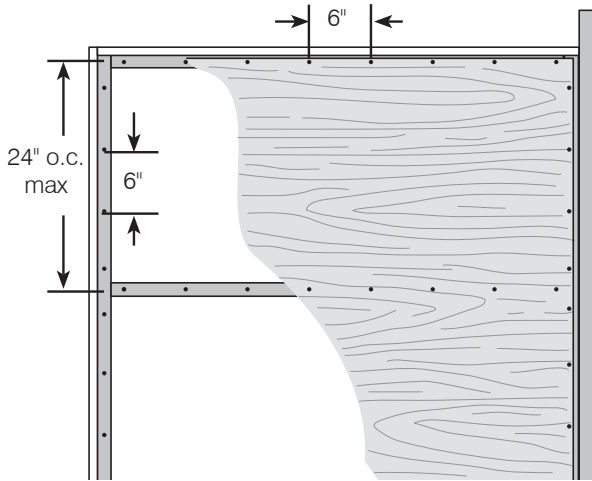

**Porch Ceiling Panel Installation**

- ▶ For easier installation, we recommend a double stud at panel joints.
- ▶ For 2x wood framing, use 6d nails (min.) spaced 6" on center at panel edges and field framing members. Do not use finishing nails.
- ▶ For light gauge steel frame construction, use #8 x 0.385" head diameter x 1-1/4" long (min.) ribbed bugle head fiber cement screws spaced 6" o.c. at panel edges and field framing members.

**Installation**

Position fasteners no closer than 3/8" from panel edges and 2" away from corners.

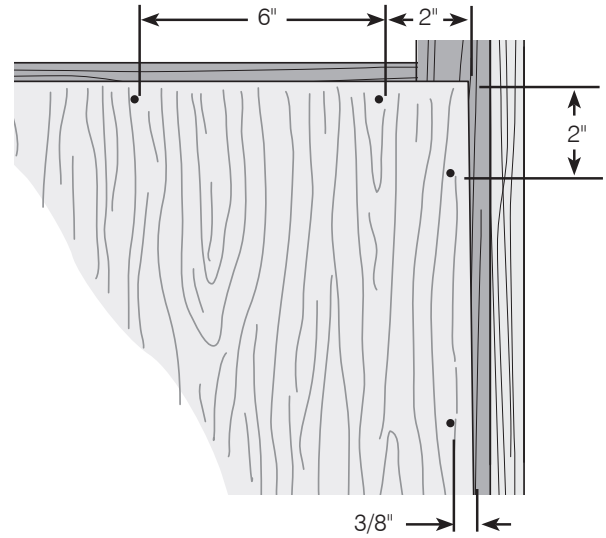

**Fastening Porch Ceiling Panels**

Position fasteners no closer than 3/8" from panel edges and 2" away from corners.

Install panels with all edges butted in moderate contact. Panels can be installed with or without battens.

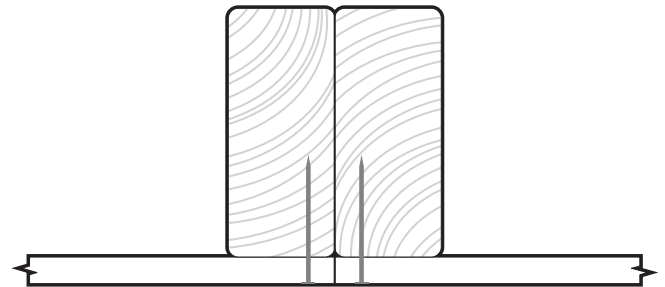

**Butted Panel Joint**

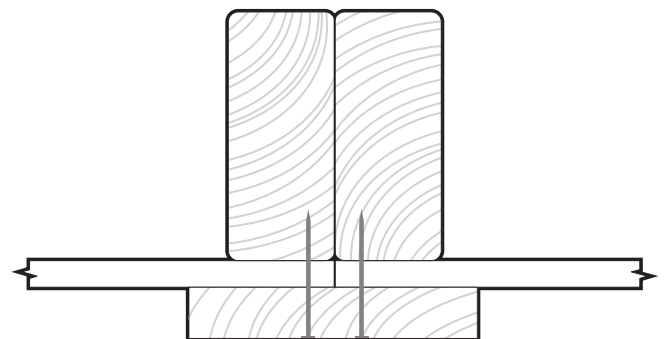

**Butted Panel Joint with Batten**

## Section 15: Finishing

### Caulking

Use a high quality, exterior-grade caulk or sealant. For 4/4 and 5/4 trim, use caulk that complies with either ASTM C834 (latex) or ASTM C920 (urethane). The caulk or sealant should be color matched or paintable. It should be compatible with both fiber cement siding and the materials used for the trim. Check the gloss and texture of the caulk to make sure it is compatible with the paint.

To ensure that caulks and sealants stay in place, we recommend using materials that remain flexible. The labels of these materials will be clearly marked with a phrase similar to “permanently flexible.”

Before you begin to caulk, remove any dust or debris. Caulk wherever siding meets the trim, at non-self-flashing penetrations, and around all windows and doors. Do not caulk areas where fiber cement siding has been inserted into J-channel or another pocket or accessory.

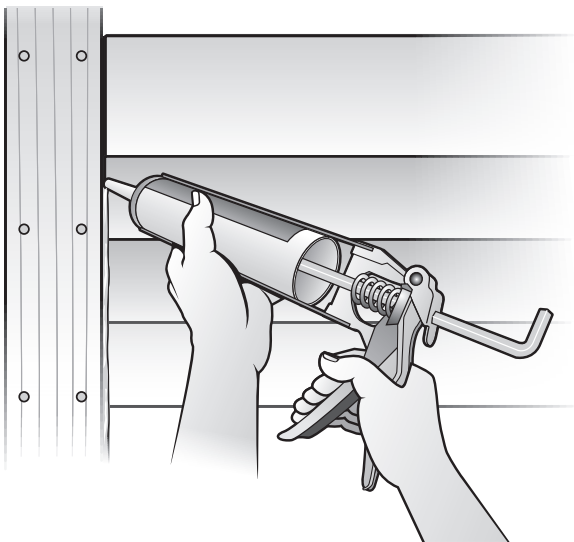

**Caulk between Siding and Trim**

- ▶ Leave a 1/8" gap between the siding and the trim.
- ▶ Caulk at all end joints around windows, doors, and the corners of the house.
- ▶ Caulk around exterior penetrations such as dryer vents, exterior lighting fixtures, pipes, electrical and cable openings, and water spigots.

- ▶ Do not caulk the bottom of the horizontal joints above the Z-flashing
- ▶ Before inserting field-cut edges into a pocket or accessory, prime or paint the edge. Do not caulk.
- ▶ Caulk edge joints at upper frieze boards and band boards.

Always follow the caulk manufacturer's directions.

#### **Do not caulk fiber cement siding butt joints/edges.**

It is never acceptable to leave a gap of any size at a butt end/joint. Butt end/joints should be installed with factory-sealed or factory-prefinished ends butted together in moderate contact. CertainTeed recommends (but does not require) the use of a butt end/joint flashing made of a durable, non-corrosive material that is compatible with fiber cement siding (e.g. #15 felt, trim coil, Bear Skin joint flashing). Check if local code requires backflashing at the butt joint.

**Do not caulk.** Applying caulk to the butt joint is ineffective because the gap is not large enough to accommodate the sealant. Also, on prefinished products, caulk may leave an unsightly looking finish. Spreading or feathering the sealant into a thin film will create a noticeably different appearance, and it can remove the needed thickness required to withstand UV exposure and joint movement.

If the architect, designer, installer, project manager, contractor, property owner, code official or other entity involved with determining the method of installation on a project determines that spacing the butt joints and applying caulk is an acceptable practice during installation, such practice will not affect the eligibility of the WeatherBoards Fiber Cement siding product installed on the project for warranty coverage with regards to product defect, provided that the caulking of the butt joints does not inflict, cause, or otherwise create a condition where this practice was, is, or becomes the cause of product failure.

**NOTE: Do not use caulk to seal nail holes.**



## Painting

All WeatherBoards Fiber Cement Siding, Soffit, and Trim is sealed with CertainTeed's FiberTect® Sealer/Primer. When the edges of field-cut fiber cement siding meet up with trim boards, the edges must be coated with a high-quality 100% acrylic latex paint or primer, and caulked.

In all other locations, field-cut edges should be coated with a high-quality 100% acrylic latex paint or primer, but **NOT** caulked.

WeatherBoards™ Fiber Cement Siding, Soffit and Trim must be allowed to breathe. Do not prime, paint, or stain the back side. Some "spill-over" from primer, paint, or stain on the back is normal.



You should apply a finish coat within 24 months of installation. On 4/4 and 5/4 fiber cement trim, apply a finish coat within 6 months of installation. Use a high-quality, 100% acrylic latex paint. Before applying the finish coat, always follow the paint manufacturer's recommendations for surface preparation and paint application.

**NOTE: Never apply oil-based paints or stains to fiber cement siding, soffit, or trim.**

## Staining

For a stained look, we highly recommend that you purchase WeatherBoards Fiber Cement Prefinished with Stain. This will give the best overall appearance and performance of the product. If you do elect to field-apply stain to primed fiber cement, we recommend that the stain be applied before installation and with the fiber cement in a horizontal, flat position. A small sampling of material should be stained and evaluated for satisfactory appearance before staining all material needed for the job.

## Section 16: Care and Maintenance

While WeatherBoards Fiber Cement siding remains a remarkably low maintenance product, the suggestions and recommendations below should be followed to achieve long-term satisfaction.

### Periodic Maintenance and Care

The siding should be inspected periodically with the following routine maintenance performed as necessary:

- ▶ Re-fasten any loose siding.
- ▶ Cut back any trees or shrubs that touch the siding.
- ▶ Replace any caulking that has hardened, cracked or lost its seal.
- ▶ Fill any small holes that may appear in the siding with high quality acrylic caulk or cementitious patch.
- ▶ Correct the drainage in any spots where water is retained in contact with the siding. Long term contact with water may result in discoloration.
- ▶ Avoid regularly wetting the siding with lawn sprinklers since water in many locales contains rust or minerals which may discolor the siding's surface, shorten the life of the paint job, and encourage the growth of mildew and fungus.

**NOTE: If the product has been finished/ painted in the field, please refer to your paint manufacturer's recommendations for care and maintenance.**

**NOTE: If the product has been pre-finished with CertainTeed ColorMax® Finish, refer to the directions provided in this document.**

## Washing

Depending on locale and climate conditions, the siding may be subject to occasional accumulations of dirt. To keep the siding attractive, we recommend periodic washing (every 6 to 12 months). Use tap water to which a moderate amount of household cleaner has been added. Apply the solution with a cloth, sponge, or soft brush (as a car wash brush). Less streaking will result if the siding is washed from bottom to top. Immediately follow all washing by rinsing thoroughly with plain water from a garden hose. Never use harsh cleaners, abrasives, or strong solvents because they may damage the paint or surface. If the dirt does not wash off, it may be mildew or a fungus growth.

**NOTE: We do not recommend power washing fiber cement siding as it can cause moisture intrusion, damage, and/or discoloration.**

## Protecting Fiber Cement Siding

### *Moisture Management and Gutters*

Water management is key to protecting every part of your home, including your siding. Each area of the country is affected by moisture, whether it's an occasional thunderstorm, high levels of rainfall or heavy snow accumulations. The resulting moisture has potential to cause damage if not managed effectively. We recommend protecting your home from rainfall with gutters and downspouts. Divert or remove heavy snow accumulations that may stand against the siding for extended periods of time. And you should always be sure that your drainage system is free of debris and working properly.

### *Shrubbery*

Proper moisture management also involves managing your landscape. Plants hold moisture, so any trees or shrubs that are close to your home should be trimmed periodically. Plants should not come into contact with your siding. Also, sprinkler systems should be adjusted to not saturate areas near your home.

## Clearances

Maintain required clearances and drainage slopes to ensure that moisture is diverted away from your siding at roof lines and ground level. Proper clearances include 1 inch from concrete, roof lines, patios, etc., and 6 inches from the finished grade. Landscaping should not reach the siding.

## Recaulking

It is normal for building products located on the exterior of a home to expand and contract with temperature changes. To ensure a successful siding installation, you must allow for this movement during installation. While CertainTeed WeatherBoards Fiber Cement siding does not experience the same rate of expansion and contraction as many other building products (such as wood), over time you may notice movement of the siding, specifically at the butt end/joints. This issue is mainly an aesthetic issue and should not create a condition that would cause long-term product failure. If you are dissatisfied with the appearance of the butt end/joint locations and wish to address them, CertainTeed recommends that you apply H-covers at the joint locations.

**NOTE: Refer to your sealant manufacturer's specifications to determine if they allow the caulking of fiber cement siding butt joints/edges, what their minimum and maximum gap requirements are, and/or how this practice may affect the warranty for the caulking.**

To ensure that caulks and sealants stay in place, we recommend using materials that remain flexible. The labels of these materials will be clearly marked with a phrase similar to "permanently flexible." For best results, use a high quality, exterior-grade caulk or sealant that meets ASTM C834 (latex caulk) or ASTM C920 (urethane caulk). The caulk or sealant should be color matched or paintable. It should be compatible with both fiber cement siding and the materials used for the trim. Check the gloss and texture of the caulk to make sure it is compatible with the paint.

Before you begin to caulk, remove any dust or debris. Caulk wherever siding meets the trim vertically at the corners and around windows and doors. Do not caulk where the siding is installed into J-channel or a pocket/ accessory. Follow the caulk manufacturer's application instructions.

## Touch-ups

### *Before You Begin*

- ▶ Check the color, amounts, and accessories in the touch-up kit.
- ▶ Mix the paint well.
- ▶ Do not allow touch-up paint to freeze.
- ▶ The paint and the panel, as well as the ambient air temperature must be 50° F or above.
- ▶ Test the color on the sample piece or hidden area of siding/trim before applying.

### *Applicators*

Use a paint pen applicator or 1" foam brush to touch-up any nicks or scratches that have occurred during installation.

Use paper funnels to fill the pen applicator and 4 oz. blotter.

Use a shoe polish/bingo type applicator and sponge tip to seal end cuts. Do not use on the board face.

Use the paint pen applicator only to touch up areas that are smaller than a dime. We recommend that you replace panels with areas of damage that are larger than a dime.

## Mildew

Mildew is an airborne fungus that attaches to and grows on various surfaces, including paint. It often gives a streaked appearance that looks like dirt on a painted surface. A simple test to confirm the presence of mildew is to place a drop of common household bleach on the stained area. Mildew will bleach out in 1 to 2 minutes; dirt will not.

Other fungus growth, such as molds, are more easily recognized since they are thicker and denser and range in color from green to brown to black.

Mildew and fungus must be killed and removed whenever they are detected, but especially before repainting since they will continue to grow through a new paint job. To remove them, use the following solution:

1. 1/3 cup detergent containing **NO ammonia**
2. 1 quart Clorox
3. 3 quarts warm water

Wear rubber gloves and goggles when applying the solution. Protect any shrubbery with a plastic drop cloth. As mildew spores can soon settle on the cleaned surface and renew their growth, a mildew resistant paint specifically recommended by your paint supplier as suitable for fiber cement siding should be applied as soon as the cleaned surface dries.

## Refinishing

Exterior wall finishes weather most rapidly on those portions of the building that receive the greatest exposure to sun and moisture. Areas receiving maximum exposure generally will need finishing sooner than other areas.

The frequency of refinishing will depend on the climate and exposure; the type, quality, and color of the paint; the method of application; and number of coats of paint. Specifically, refinishing is indicated if: the surface is discolored and blotchy; the coating is cracked, peeling or scaling; or the coating appears thin or porous and is chalked to the point where it no longer protects or hides the surface.

## Surface Preparation

The degree and type of required surface preparation depends on the condition of the old finish. Loose paint material should be removed by sanding and scraping. The surface should be cleaned before painting as described in the Washing section. If the old surface is sound, re-priming is typically not necessary.

Use only top quality, exterior type, acrylic latex primers. Confirm the compatibility of your primer and finish coats with your paint supplier. CertainTeed recommends 100% acrylic latex primer and paint system, using only the highest grade paints. Check with your paint supplier for compatibility with fiber cement siding.

## Efflorescence

### What Is It?

Efflorescence is a naturally occurring, white, powdery deposit that can appear on cement-based building materials (including bricks, cement walls, grout, and fiber cement). It is the result of a process in which moisture draws salt crystals to the surface, evaporates, and leaves a chalky substance behind.

Efflorescence occurs when all three of the following conditions exist:

1. Water-soluble salts are present in the building material.
2. There is enough moisture in the wall to turn the salts into a soluble solution.
3. There is a path for the soluble salts to get to the surface.

Efflorescence may also be a sign of water intrusion behind the siding. Make certain that all openings are properly flashed and there is no water intrusion due to over-driven nails.

### What Can Be Done about It?

While some efflorescence may weather away naturally on its own, it is best to take steps to treat it using one of the methods described.

#### Vinegar and Water Solution

Efflorescence can be removed with a dilute solution of household white vinegar and water. The dilution ratio is 20 to 50% vinegar in water by volume. For most cases of efflorescence, a 25% solution works well.

For best results, follow these cleaning instructions:

1. Spray all plants and vegetation with water before and after application of the vinegar/water solution.
2. Protect areas that will not be cleaned.
3. Wet the surfaces to be cleaned with water and let stand for 5 to 10 minutes. Flood the entire surface area to be cleaned with vinegar and water solution.
4. Allow the solution to sit on the surface for 10 minutes.
5. Rinse the treated area with water from the top down.

For extra tough efflorescence, a second application or light scrubbing may be required. Use a soft bristled brush or sponge and lightly scrub the area. Do not aggressively scrub as this may damage the surface of the painted product. Rinse thoroughly with water and allow the area to air dry. If necessary, repeat these steps until you've reached the desired outcome.

#### House Washes

Commercially produced house wash solutions that may also be used to safely treat efflorescence are available. Follow the manufacturer's instructions to ensure that the product is suitable for use on fiber cement.

Complete product details, including technical information, installation guidelines and warranties, are available at [certainteed.com](http://certainteed.com) or at 800-233-8990.









Scan for our latest WeatherBoards™ Fiber Cement Installation video.

buildingresponsibly™

**ASK ABOUT OUR OTHER CERTAINTEED PRODUCTS AND SYSTEMS:**

**EXTERIOR:** ROOFING • SIDING • WINDOWS • FENCE • RAILING • TRIM • DECKING • FOUNDATIONS • PIPE  
**INTERIOR:** INSULATION • GYPSUM • CEILINGS

CertainTeed Corporation  
P.O. Box 860  
Valley Forge, PA 19482

Professional: 800-233-8990  
Consumer: 800-782-8777  
[www.certainteed.com](http://www.certainteed.com)

**CertainTeed** 